

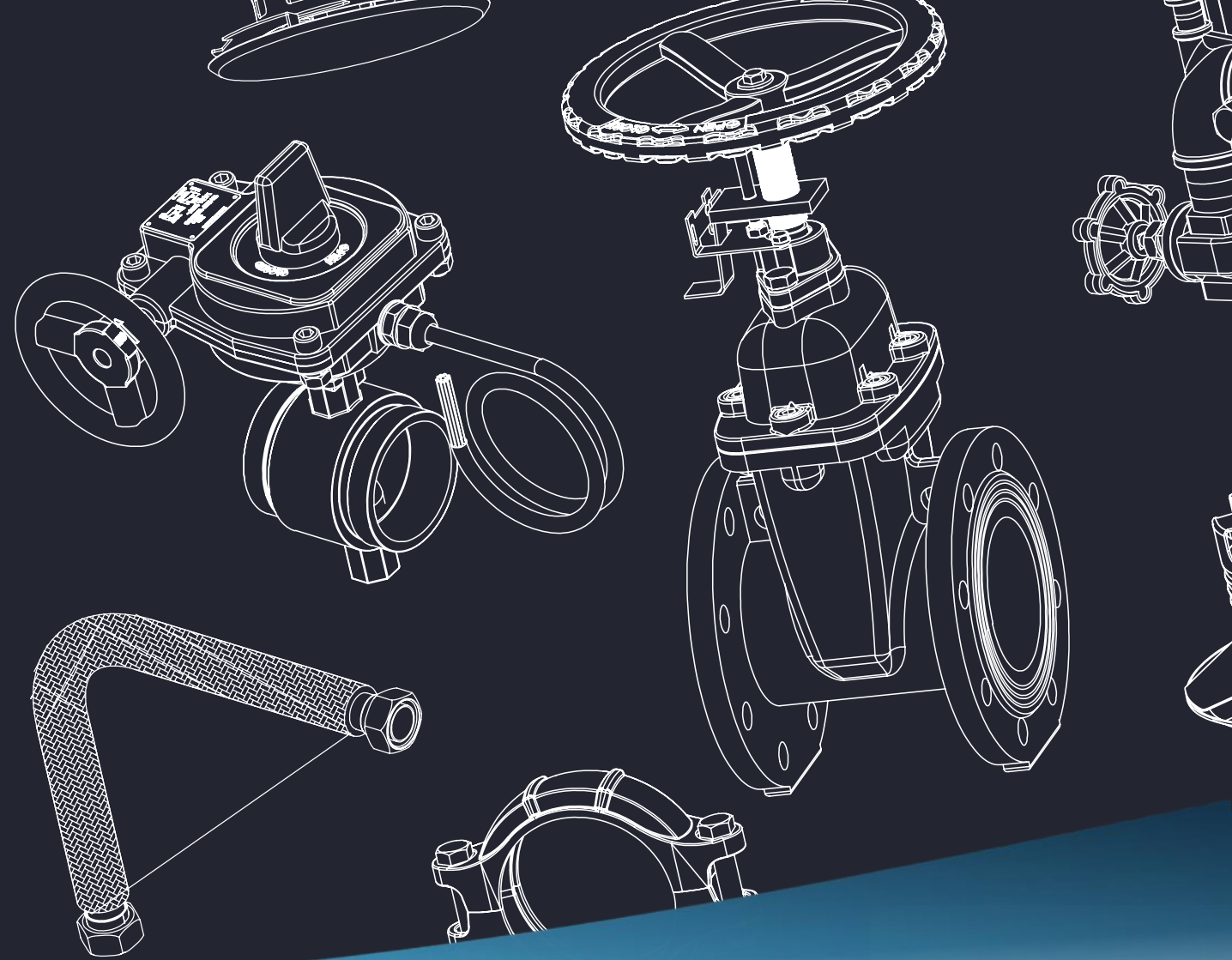

# Group Facilities Manager

June 2026



# Join Rapidrop

## A Global Leader in Fire Protection Innovation

At Rapidrop, we are proud to be a British manufacturer and global supplier of high-quality fire sprinklers and fire suppression equipment. From our headquarters in Peterborough, Cambridgeshire, we support customers in over 75 countries with reliable, internationally approved fire safety solutions.

Our product range, including UK-manufactured sprinkler heads, valves, flexible hose systems and specialist fire protection components, has built a strong reputation for quality, innovation, technical expertise and our customer-centric approach.

We are committed to protecting lives and property, with our systems installed around the world and contributing to major commercial developments and landmark projects.

IFI, the original foundation of Rapidrop, supports the construction and fenestration industry by supplying specialists and installers with a comprehensive range of fixings, fitting tools and consumables. Over the past eighteen months, Rapidrop has entered an exciting new phase of growth, welcoming a new CEO and Chairman alongside significant investment and long-term expansion plans. This includes new storage facilities in the UAE, increased European capacity and a new product development programme to expand our range and improve availability.

Today, our teams operate across the UK, Europe, the Middle East and South Africa, supported by continued investment in our UK headquarters, including a fully refurbished modern office environment. With a collaborative culture and a growing international footprint, Rapidrop offers an exciting opportunity to contribute to a business focused on innovation, growth and protecting people and property worldwide.



**The Shard, United Kingdom**



**Mall of Istanbul, Turkey**

# Role Overview

**Location:** Peterborough with international travel

**Contract:** Permanent

**Reports to:** Group Warehouse Manager

As Group Facilities Manager, you will play a key role in ensuring Rapidrop's global facilities operate safely, efficiently and in line with the needs of a growing international business.

Working across our Peterborough headquarters, Leeds warehouse, UAE operations and third-party global locations, you will oversee facilities management, maintenance, workplace services, fleet operations, health and safety compliance and supplier performance.

Working closely with internal stakeholders and external contractors, you will support the delivery of facilities strategies that enhance operational performance, maintain high workplace standards and support business growth.

This position offers an exciting opportunity for a commercially aware and operationally focused facilities professional who enjoys managing multiple sites, driving continuous improvement and creating safe, compliant and well-maintained working environments.

The role will involve occasional UK and international travel to support facilities operations, projects and business requirements across Rapidrop's global network.



**Agbar Tower, Spain**



**Hilton Airport, Amsterdam, Netherlands**

# Key Responsibilities

- Lead and oversee facilities operations across Rapidrop's global sites, ensuring high standards of workplace safety, compliance and operational performance.
- Manage facilities services across the Peterborough headquarters, Leeds warehouse, UAE operations and third-party global locations.
- Develop and implement facilities strategies that support business growth, operational efficiency and workplace standards.
- Manage supplier, contractor and service provider relationships to ensure effective service delivery, value for money and compliance with agreed standards.
- Oversee maintenance programmes, workplace services, fleet operations and facilities infrastructure across all locations.
- Ensure compliance with health and safety legislation, risk management processes, environmental requirements and operational policies.
- Identify and deliver continuous improvement initiatives that enhance facilities performance, workplace environments and operational efficiency.



**Wembley Stadium, United Kingdom**

# Experience & Expertise

## Essential

- Proven experience within facilities management, operations or multi-site facilities environments.
- Strong understanding of facilities maintenance, compliance, workplace services and operational best practice.
- Experience managing contractors, suppliers and external service providers to deliver high service standards.
- Experience supporting health and safety compliance within operational or industrial environments.
- Strong organisational, project management and stakeholder engagement skills.
- Commercially aware with strong problem-solving capability and the ability to manage multiple priorities across multiple sites.



VIMD Kvar, Zagreb, Croatia

## Desirable

- Experience within manufacturing, logistics, warehousing, industrial or distribution environments.
- OSH, NEBOSH or equivalent health and safety qualification.
- Experience managing facilities operations across international locations.
- Experience leading facilities improvement, sustainability or workplace enhancement projects.



Heathrow Airport, Terminal 5, United Kingdom

# Why Join Rapidrop?

Rapidrop is a growing international business with a strong reputation for quality, innovation and reliability within the global fire protection industry. As the company continues its global expansion, we are investing in our people, products and capabilities to support long-term growth.

Joining Rapidrop means becoming part of a collaborative and ambitious team, where individuals are encouraged to contribute ideas, take ownership of their work and make a meaningful impact on the business.

This is an exciting opportunity to play a role in shaping the next stage of Rapidrop's international growth, working alongside experienced colleagues across multiple markets and functions.

## What We Offer

- £45k-£55k DOE
- Company pension total 8% (Employee contributions 3% Rapidrop Global contributions 5%)
- Annual leave 20-25 days (pro rata), Christmas shutdown (up to 3 days annual leave to be kept back to facilitate this)
- Death in service benefit –4 x annual salary from day 1
- International travel opportunities
- Opportunities for professional development and career progression
- Employee Assistance Program –Access to full support services 24/7, shopping rewards, health cash plan, access to online Dr Appointments



**Galeria Korona, Poland**

# Ready To Apply?

If you are excited about the opportunity to join Rapidrop and feel your experience aligns with the role, we would love to hear from you.

## Our Recruitment Process

### 1. Apply

Please [click here to submit](#) your CV and a short supporting statement

### 2. Review

Applications are reviewed on a rolling basis and interviews may take place before the closing date, so early applications are encouraged.

### 3. Initial Conversation

Shortlisted candidates will be invited to an introductory discussion via Teams.

### 4. Interviews

Candidates progressing will attend two formal interview with key stakeholders at our Head Office in Peterborough or via Teams.

### 5. Outcome

A final decision will be made and candidates will be informed as soon as possible.



## Inclusive Recruitment

Rapidrop is committed to creating an inclusive and supportive workplace where everyone feels valued, respected and able to thrive. We welcome applications from people of all backgrounds, experiences and perspectives, recognising that diversity strengthens our teams and drives innovation.

If you require any adjustments or support at any stage of the recruitment process, please let us know. We are committed to ensuring every candidate has a fair and positive experience.

**Good luck with your application. We look forward to receiving your application and exploring how you could contribute to Rapidrop's continued growth and success.**