

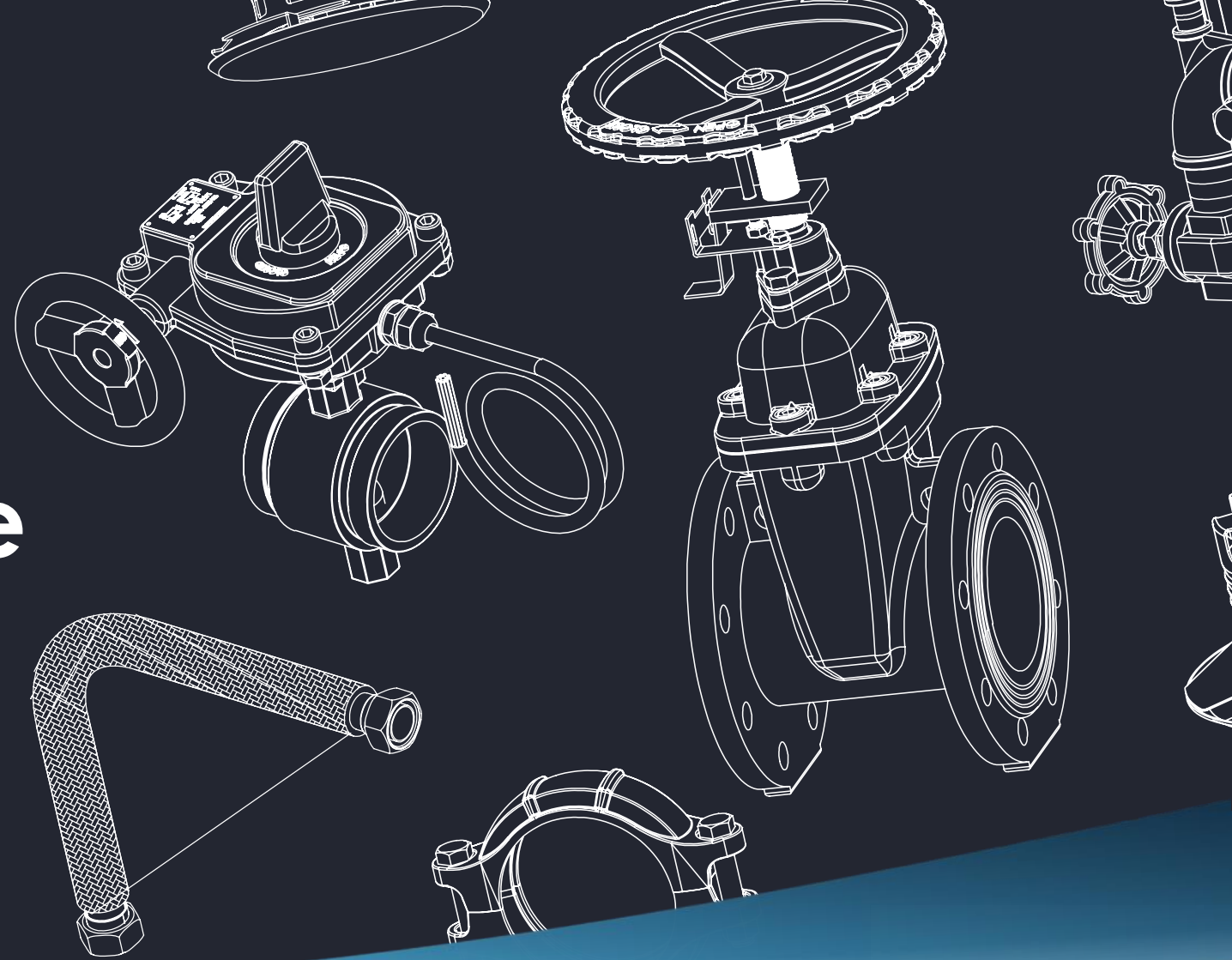

Group Warehouse Manager

June 2026



Join Rapidrop

A Global Leader in Fire Protection Innovation

At Rapidrop, we are proud to be a British manufacturer and global supplier of high-quality fire sprinklers and fire suppression equipment. From our headquarters in Peterborough, Cambridgeshire, we support customers in over 75 countries with reliable, internationally approved fire safety solutions.

Our product range, including UK-manufactured sprinkler heads, valves, flexible hose systems and specialist fire protection components, has built a strong reputation for quality, innovation, technical expertise and our customer-centric approach.

We are committed to protecting lives and property, with our systems installed around the world and contributing to major commercial developments and landmark projects.

IFI, the original foundation of Rapidrop, supports the construction and fenestration industry by supplying specialists and installers with a comprehensive range of fixings, fitting tools and consumables. Over the past eighteen months, Rapidrop has entered an exciting new phase of growth, welcoming a new CEO and Chairman alongside significant investment and long-term expansion plans. This includes new storage facilities in the UAE, increased European capacity and a new product development programme to expand our range and improve availability.

Today, our teams operate across the UK, Europe, the Middle East and South Africa, supported by continued investment in our UK headquarters, including a fully refurbished modern office environment. With a collaborative culture and a growing international footprint, Rapidrop offers an exciting opportunity to contribute to a business focused on innovation, growth and protecting people and property worldwide.



The Shard, United Kingdom



Mall of Istanbul, Turkey

Role Overview

Location: Peterborough with international travel

Contract: Permanent

Reports to: Sales Director

As Group Warehouse Manager, you will play a key role in leading Rapidrop's global warehousing and logistics operations, ensuring the efficient movement, storage and control of inventory across our international network.

Working closely with senior stakeholders across operations, procurement, supply chain, finance and sales, you will develop and implement warehousing and logistics strategies that support Rapidrop's ambitious growth plans.

The role oversees warehouse operations across our UK and UAE facilities, together with third-party logistics partners in South Africa, Denmark and the Netherlands, ensuring high standards of operational performance, stock accuracy and customer service.

This position offers an exciting opportunity for an operationally focused leader who enjoys managing complex international operations, driving continuous improvement and developing high-performing teams.

The role will involve occasional international travel to support warehouse operations, logistics partners, operational projects and business growth initiatives.



Agbar Tower, Spain



Hilton Airport, Amsterdam, Netherlands

Key Responsibilities

- Lead and oversee warehouse operations across Rapidrop's global warehouse network, ensuring high standards of operational efficiency, service delivery and inventory accuracy.
- Manage warehouse activity across the UK and UAE facilities, alongside third-party logistics providers in South Africa, Denmark and the Netherlands.
- Develop and implement warehousing and logistics strategies that support business growth, operational performance and customer requirements.
- Ensure robust inventory management, stock control and warehouse systems are in place across all locations.
- Lead, motivate and develop warehouse teams whilst building strong relationships with third-party logistics providers and key internal stakeholders.
- Monitor warehouse performance, logistics activity and operational KPIs, driving continuous improvement initiatives and operational excellence.
- Support sourcing, freight and global logistics activities, ensuring the efficient, cost-effective and compliant movement of goods worldwide.



Wembley Stadium, United Kingdom

Experience & Expertise

Essential

- Proven experience leading warehouse, logistics or supply chain operations within a manufacturing, distribution or operational environment.
- Experience managing multi-site warehouse operations and third-party logistics providers.
- Strong understanding of inventory management, stock control, warehousing best practice and operational KPIs.
- Experience overseeing international logistics, freight and global movement of goods.
- Demonstrated ability to lead, develop and motivate teams while building strong stakeholder relationships.
- Strong commercial awareness, organisational capability and problem-solving skills, with the ability to manage multiple priorities across international operations.



VIMD Kvar, Zagreb, Croatia

Desirable

- Experience implementing or leading a Warehouse Management System (WMS) project.
- Experience within manufacturing, engineering, construction products or industrial distribution sectors.
- Knowledge of continuous improvement methodologies and operational excellence principles.



Heathrow Airport, Terminal 5, United Kingdom

Why Join Rapidrop?

Rapidrop is a growing international business with a strong reputation for quality, innovation and reliability within the global fire protection industry. As the company continues its global expansion, we are investing in our people, products and capabilities to support long-term growth.

Joining Rapidrop means becoming part of a collaborative and ambitious team, where individuals are encouraged to contribute ideas, take ownership of their work and make a meaningful impact on the business.

This is an exciting opportunity to play a role in shaping the next stage of Rapidrop's international growth, working alongside experienced colleagues across multiple markets and functions.

What We Offer

- Salary to £70k DOE
- Company pension total 8% (Employee contributions 3% Rapidrop Global contributions 5%)
- Annual leave 20-25 days (pro rata), Christmas shutdown (up to 3 days annual leave to be kept back to facilitate this)
- Death in service benefit –4 x annual salary from day 1
- International travel opportunities
- Opportunities for professional development and career progression
- Employee Assistance Program –Access to full support services 24/7, shopping rewards, health cash plan, access to online Dr Appointments



Galeria Korona, Poland

Ready To Apply?

If you are excited about the opportunity to join Rapidrop and feel your experience aligns with the role, we would love to hear from you.

Our Recruitment Process

1. Apply

Please [click here to submit](#) your CV and a short supporting statement

2. Review

Applications are reviewed on a rolling basis and interviews may take place before the closing date, so early applications are encouraged.

3. Initial Conversation

Shortlisted candidates will be invited to an introductory discussion via Teams.

4. Interviews

Candidates progressing will attend two formal interview with key stakeholders at our Head Office in Peterborough or via Teams.

5. Outcome

A final decision will be made and candidates will be informed as soon as possible.



Inclusive Recruitment

Rapidrop is committed to creating an inclusive and supportive workplace where everyone feels valued, respected and able to thrive. We welcome applications from people of all backgrounds, experiences and perspectives, recognising that diversity strengthens our teams and drives innovation.

If you require any adjustments or support at any stage of the recruitment process, please let us know. We are committed to ensuring every candidate has a fair and positive experience.

Good luck with your application. We look forward to receiving your application and exploring how you could contribute to Rapidrop's continued growth and success.