

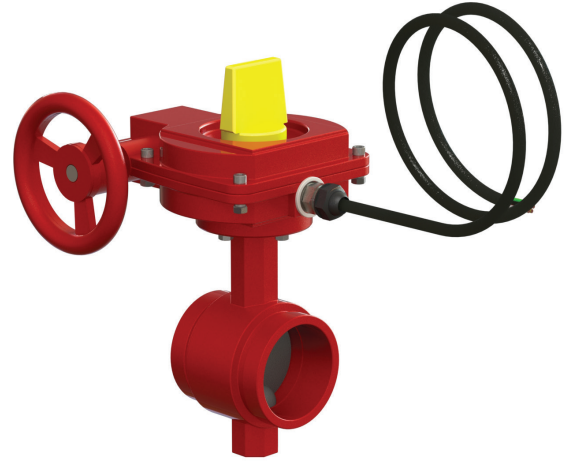

## Grooved Butterfly Valve Fig. 216

### Product Description

Rapidrop Figure 216 Grooved Butterfly Valve is a rotary type valve with a visual indication of whether the valve is in fully open position or not. Butterfly valves are commonly used in fire protection systems as system control valves, sectional or pump water control valves. These valves have been designed with minimum flow restriction and pressure loss when in fully open position. To reduce the risk of a water hammer Rapidrop Butterfly Valves are provided with a slow close hand wheel operated gearbox. Valves supplied as standard with a 1m flying lead.



### Maximum Working Pressure

20.7 bar (300 psi) FM Approved, UL Listed, CNBOP  
16.0 bar (232 psi) VdS

### Temperature Range

0° - 80°C

### Coating

Fusion Bonded Epoxy Coating in accordance with ANSI /AWWA C550

### Design Standard

MSS SP-67

### Connections

Groove to ISO6182 / AWWA C606

### Gearbox Mounting Flange

ISO 5211

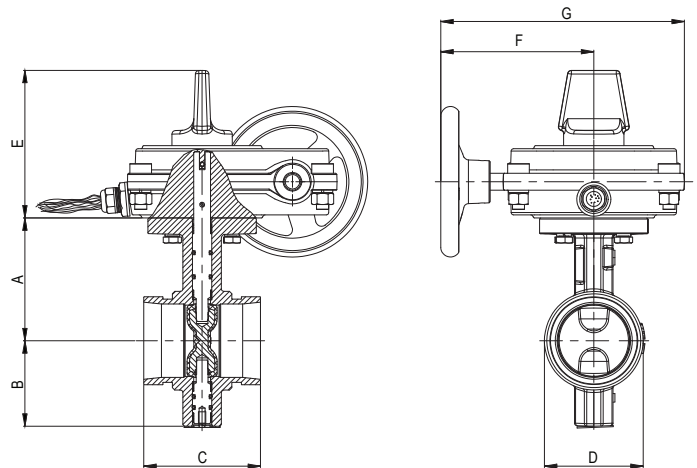

### Dimensions

Sizes		Dimensions (mm)							Weight (Kg)	Product Ordering Code
mm	Inch	A	B	C	D	E	F	G		
DN 50	2"	89	65	81±1.5	60.3	123	127	202	8.0	RD216-050FL
DN 65 *	2 1/2" *	102	71	97±1.5	73.0	123	127	202	8.6	RD216-073FL
DN 65	2 1/2"	102	71	97±1.5	76.1	123	127	202	8.6	RD216-065FL
DN 80	3"	109	81	97±1.5	88.9	123	127	202	9.2	RD216-080FL
DN 100	4"	128	95	116±1.5	114.3	123	127	202	10.7	RD216-100FL
DN 125	5"	141	111	148±1.5	139.7	123	127	202	13.7	RD216-125FL
DN 150*	6" *	153	133	148±1.5	165.1	123	127	202	18.1	RD216-150FL
DN 150	6"	153	133	148±1.5	168.3	123	127	202	18.1	RD216-168FL
DN 200	8"	184	164	133±1.5	219.1	123	185	260	22.7	RD216-200FL
DN 250	10"	216	196	159±1.5	273.0	123	185	260	33.7	RD216-250FL
DN 300	12"	254	226	165±1.5	323.9	132	203	298	48.6	RD216-300FL

\* Not VdS Approved

# Grooved Butterfly Valve

## Fig. 216

### Installation

Rapidrop Figure 216 Grooved Butterfly Valve is suitable for indoor and outdoor use. The valve may be installed in any position and the flow may be from either direction through the valve. Valves should be supported independently to prevent the movement and stresses from the connecting piping system.

1. Ensure that the valve is in closed or almost closed position.
2. Visually inspect the valve, make sure the seating area is not damaged and that the connecting faces are clean of debris and any foreign materials.
3. Using appropriate grooved couplings connect the valve with adjacent pipe or fitting. Follow the instructions supplied by the manufacturer of the couplings.
4. Check the operation by fully opening and closing the valve.

### Care and Maintenance

Rapidrop butterfly valves require no regular maintenance, however it is advisable to inspect and verify proper operation of the unit annually or in accordance with the authority having jurisdiction.

The inspection should include a visual check for leakage at the pipe connection and body to gearbox connection. Inspection and maintenance should be performed by a competent person in accordance with national codes/ requirements.

Debris in the piping system might cause difficulties in closing the valve, this problem can be fixed by backing off the handwheel and closing the valve again.

Rapidrop Figure 216 Grooved Butterfly Valves are suitable for both indoor and outdoor use. Minor degradations of surface finish should not affect the performance of the valve.

The valve should never be forced to seat by applying a wrench to the hand wheel as this may distort the valve components. The use of excessive force to open or close the valve violates all warranties.

The valve should not be used to force a pipeline into position as this may result in the distortion of the valve body.

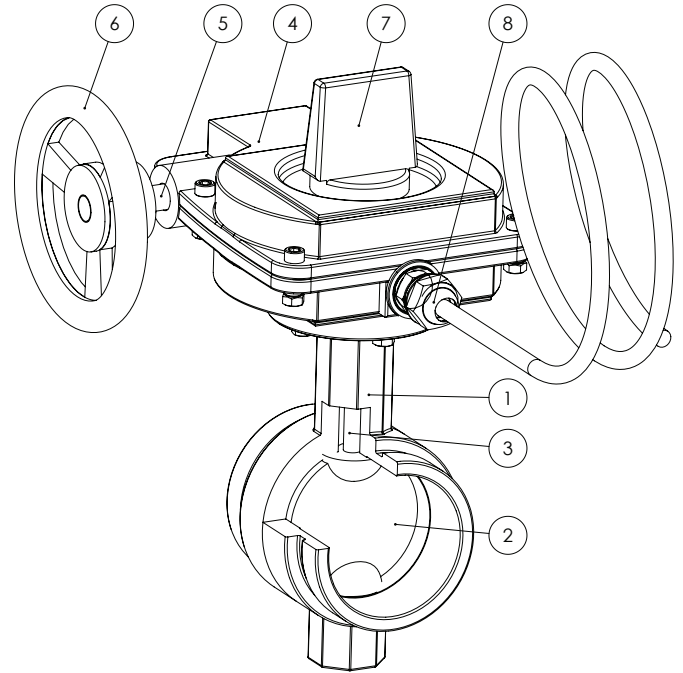

### Material Specification

No	Description	Materials
1	Valve Body	Ductile Iron
2	Disc	Ductile Iron + EPDM
3	Stem	Stainless Steel
4	Gearbox	Ductile Iron
5	Handwheel Shaft	SS431
6	Handwheel	Ductile Iron
7	Indicator	Ductile Iron
8	Cable Gland	Plastic



## Grooved Butterfly Valve Fig. 216

### Switch Installation

An internal, factory installed, double tamper switch with 1m cables provide easy supervision of the valve. Within two handwheel turns from the "OPEN" position the switch will close indicating that the valve is not fully open.

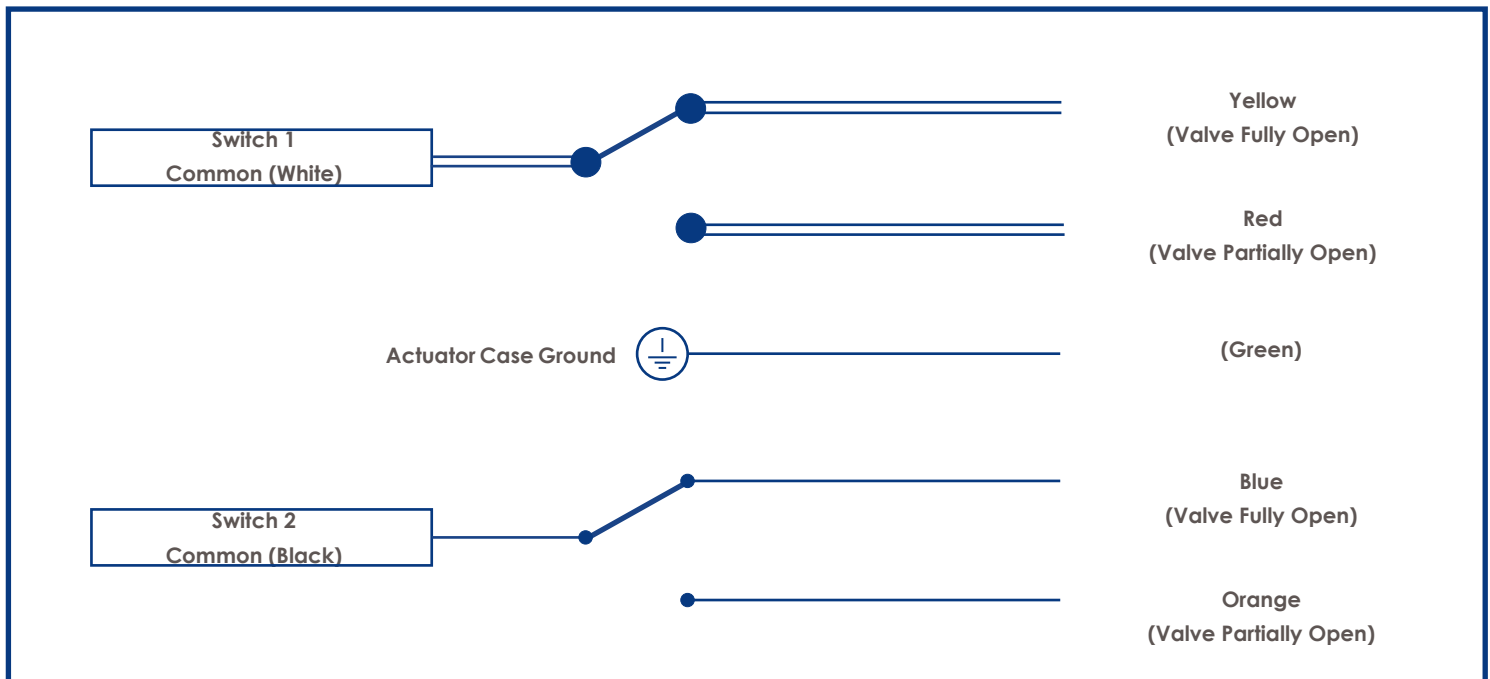

### Important Installation Information

- Rapidrop Figure 216 Grooved Butterfly Valve must only be installed by a competent person in accordance with requirements of the local authority having jurisdiction. Deviations from these standards will invalidate warranty.
- It is the responsibility of the installing contractor to include a copy of this document in the sprinkler system installation, operating and maintenance manual.
- Alterations to Rapidrop products will void any warranty.
- Figure 216 Grooved Butterfly Valve should be inspected and maintained during routine sprinkler system inspections by a competent person in accordance with national codes/requirements.
- Failure to follow these instructions could cause improper operation, resulting in personal injury and/or property damage.
- For further details and technical support please contact your Rapidrop sales representative.