

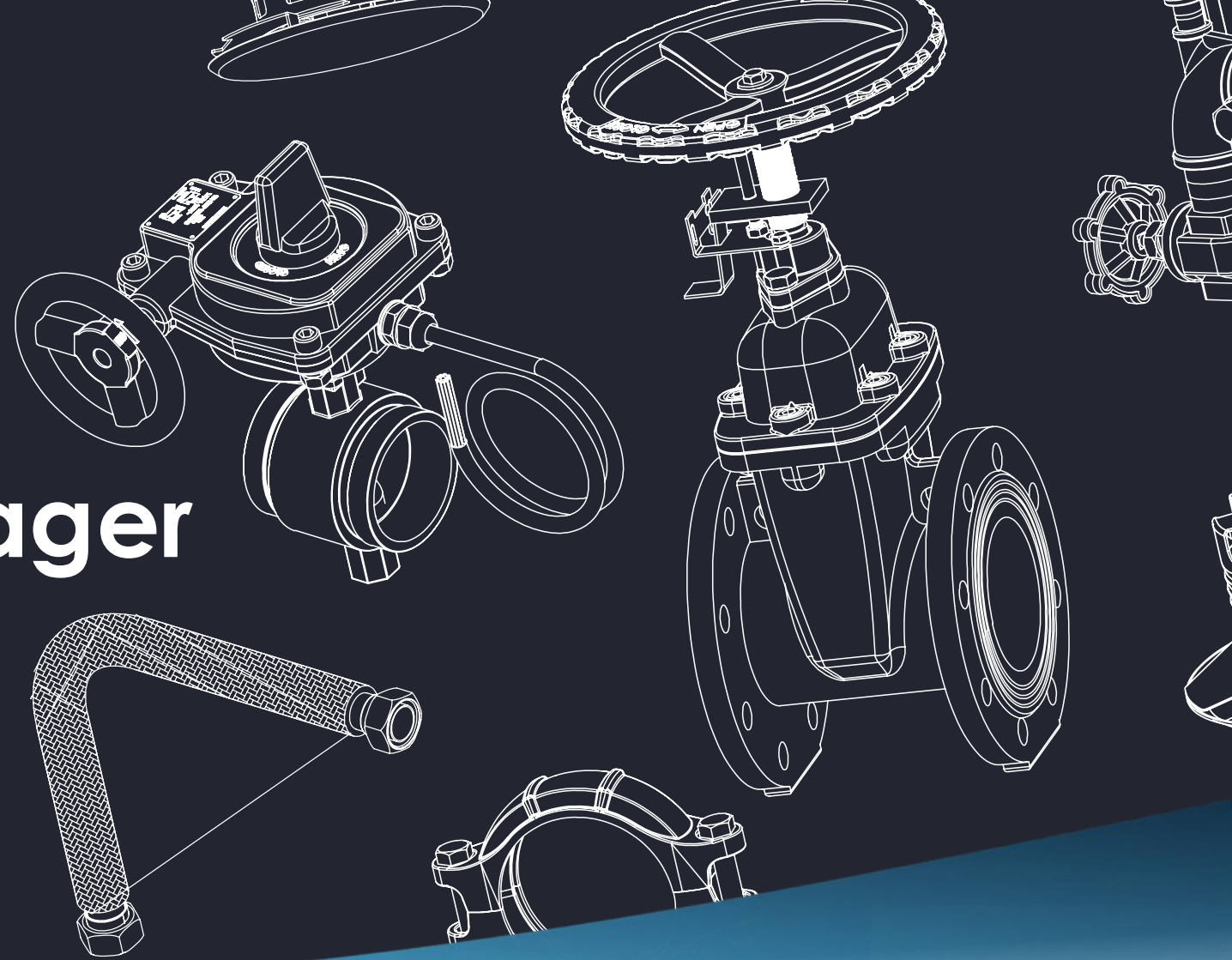

# Senior FP&A Manager

March 2026



# Join Rapidrop

## A Global Leader in Fire Protection Innovation

At Rapidrop, we are proud to be a British manufacturer and global supplier of high-quality fire sprinklers and fire suppression equipment. From our headquarters in Peterborough, Cambridgeshire, we support customers in over 75 countries with reliable, internationally approved fire safety solutions.

Our product range, including UK-manufactured sprinkler heads, valves, flexible hose systems and specialist fire protection components, has built a strong reputation for quality, innovation, technical expertise and our customer-centric approach.

We are committed to protecting lives and property, with our systems installed around the world and contributing to major commercial developments and landmark projects.

IFI, the original foundation of Rapidrop, supports the construction and fenestration industry by supplying specialists and installers with a comprehensive range of fixings, fitting tools and consumables. Over the past eighteen months, Rapidrop has entered an exciting new phase of growth, welcoming a new CEO and Chairman alongside significant investment and long-term expansion plans. This includes new storage facilities in the UAE, increased European capacity and a new product development programme to expand our range and improve availability.

Today, our teams operate across the UK, Europe, the Middle East and South Africa, supported by continued investment in our UK headquarters, including a fully refurbished modern office environment. With a collaborative culture and a growing international footprint, Rapidrop offers an exciting opportunity to contribute to a business focused on innovation, growth and protecting people and property worldwide.



**The Shard, United Kingdom**



**Mall of Istanbul, Turkey**

# Role Overview

**Location:** Peterborough

**Contract:** Permanent

**Reports to:** Chief Finance Officer

The **Senior FP&A Manager** is responsible for developing and leading Rapidrop's financial planning and performance reporting capability across the Group's UK, EU and Dubai businesses.

Working closely with senior leadership, this position provides financial insight to support strategic decision-making through clear analysis of financial performance, operational trends and commercial drivers. The successful candidate will develop budgeting/forecasting models, produce Board-level reporting with the use of clear KPI frameworks that support effective decision-making. The role will work closely with Executives, senior management, investor and Board members and other key stakeholders to provide insight and clarity on business performance. This includes supporting the organisation in understanding performance across key financial and operational areas, including manufacturing, supply chain, sales and global distribution.

The position includes line management of an FP&A Analyst, ensuring high-quality financial analysis, reporting accuracy and the ongoing development of capability within the FP&A function.

The Senior FP&A Manager plays a key part in supporting strategic decision-making by providing clear financial insight to senior leadership and Private Equity stakeholders.

The post holder is expected to work collaboratively across the business and contribute to the ongoing development and improvement of Rapidrop's financial planning, reporting and decision-making processes. Responsibilities may evolve in line with business needs and the continued development of the position.



# Key Responsibilities

- Lead and deliver the Group's budgeting, forecasting and long-range planning processes, ensuring alignment across profit and loss, balance sheet and cash flow.
- Provide clear, data-driven financial insight to support strategic decision-making, including pricing, investment appraisal and operational improvement initiatives.
- Prepare and present high-quality monthly Executive and Board-level reporting packs, clearly highlighting performance drivers, risks, opportunities and forward-looking insights.
- Act as a trusted finance business partner to senior leadership, working closely with Operations, Supply Chain, Commercial and Sales teams to understand and improve business performance.
- Analyse and interpret key financial and operational metrics, including margin, product mix, inventory and working capital, to support profitable growth.
- Lead, manage and develop the FP&A Analyst while driving continuous improvement across financial planning, reporting processes, data integrity and automation.



**Wembley Stadium, United Kingdom**

# Experience & Expertise

## Essential

- Fully qualified accountant (ACA, ACCA or CIMA) with strong post-qualification experience in FP&A or commercial finance roles.
- Proven experience leading budgeting, forecasting and financial planning processes within a multi-entity environment.
- Strong financial modelling capability with advanced Excel skills and the ability to work with complex financial data.
- Experience preparing and presenting Executive or Board-level reporting, translating financial data into clear, actionable insight.
- Strong commercial acumen and stakeholder management skills, with experience partnering senior leaders across operational or commercial functions.

## Desirable

- Background in a manufacturing, engineering or operationally focused environment.
- Exposure to Private Equity-backed or high-growth organisations.
- A track record of improving financial processes, reporting frameworks or systems, including automation or use of BI tools.



VIMD Kwart, Zagreb, Croatia



Heathrow Airport, Terminal 5, United Kingdom

# Why Join Rapidrop?

Rapidrop is a growing international business with a strong reputation for quality, innovation and reliability within the global fire protection industry. As the company continues its global expansion, we are investing in our people, products and capabilities to support long-term growth.

Joining Rapidrop means becoming part of a collaborative and ambitious team, where individuals are encouraged to contribute ideas, take ownership of their work and make a meaningful impact on the business.

This is an exciting opportunity to play a role in shaping the next stage of Rapidrop's international growth, working alongside experienced colleagues across multiple markets and functions.

## What We Offer

- Competitive salary
- Company pension total 8% (Employee contributions 3% Rapidrop Global contributions 5%)
- Annual leave 20-25 days (pro rata), Christmas shutdown (up to 3 days annual leave to be kept back to facilitate this)
- Death in service benefit –4 x annual salary from day 1
- International travel opportunities
- Opportunities for professional development and career progression
- Employee Assistance Program –Access to full support services 24/7, shopping rewards, health cash plan, access to online Dr Appointments



# Ready To Apply?

If you are excited about the opportunity to join Rapidrop and feel your experience aligns with the role, we would love to hear from you.

## Our Recruitment Process

- 1. Apply**  
Please [click here to submit](#) your CV and a short supporting statement
- 2. Review**  
Applications are reviewed on a rolling basis and interviews may take place before the closing date, so early applications are encouraged
- 3. Initial Conversation**  
Shortlisted candidates will be invited to an introductory discussion via Teams
- 4. Interviews**  
Candidates progressing will attend two formal interview with key stakeholders at our Head Office in Peterborough or via Teams
- 5. Outcome**  
A final decision will be made and candidates will be informed as soon as possible

## Inclusive Recruitment

Rapidrop is committed to creating an inclusive and supportive workplace where everyone feels valued, respected and able to thrive. We welcome applications from people of all backgrounds, experiences and perspectives, recognising that diversity strengthens our teams and drives innovation.

If you require any adjustments or support at any stage of the recruitment process, please let us know. We are committed to ensuring every candidate has a fair and positive experience.

**Good luck with your application. We look forward to receiving your application and exploring how you could contribute to Rapidrop's continued growth and success.**

