

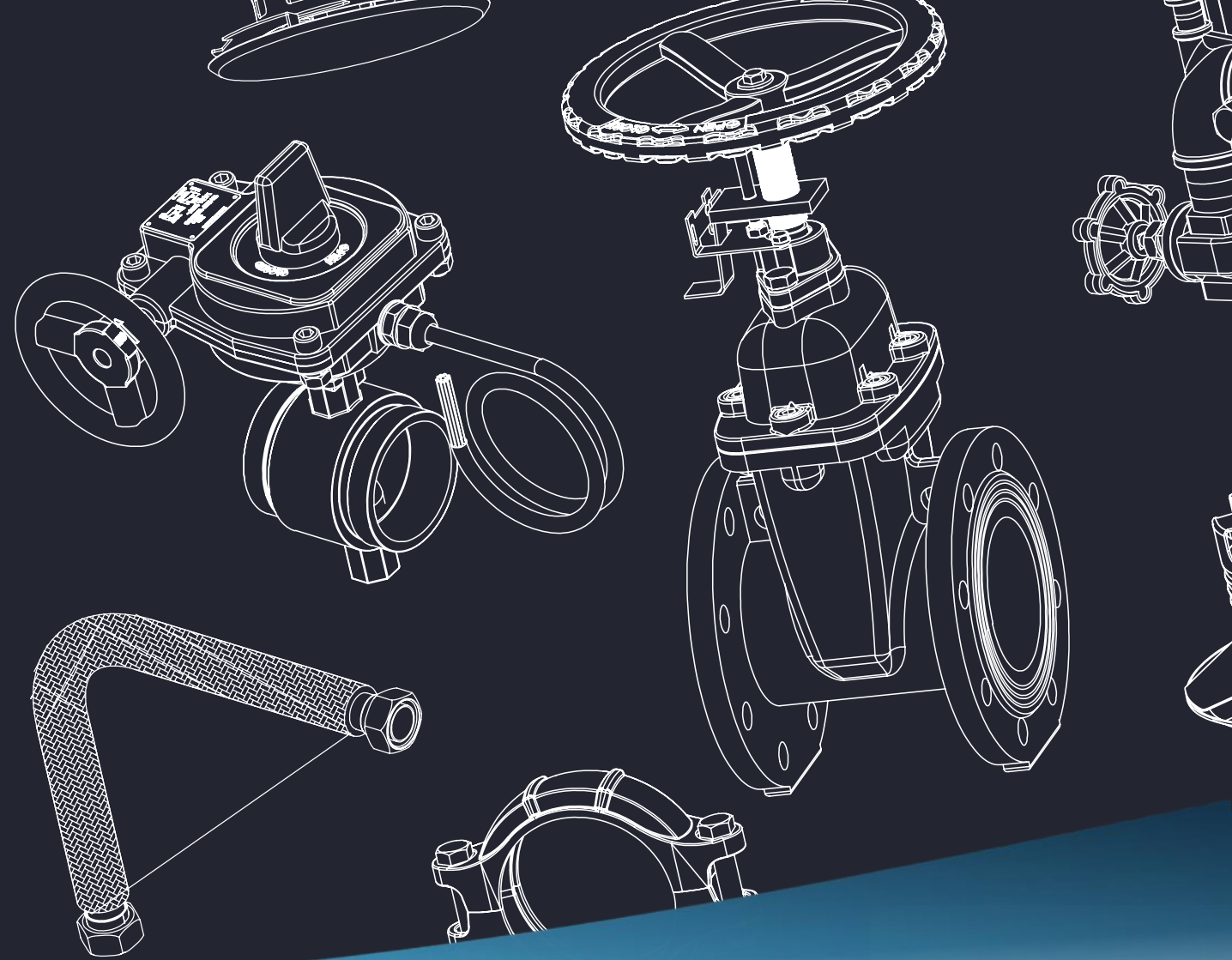

# Global Marketing Manager

March 2026



# Join Rapidrop

## A Global Leader in Fire Protection Innovation

At Rapidrop, we are proud to be a British manufacturer and global supplier of high-quality fire sprinklers and fire suppression equipment. From our headquarters in Peterborough, Cambridgeshire, we support customers in over 75 countries with reliable, internationally approved fire safety solutions.

Our product range, including UK-manufactured sprinkler heads, valves, flexible hose systems and specialist fire protection components, has built a strong reputation for quality, innovation, technical expertise and our customer-centric approach.

We are committed to protecting lives and property, with our systems installed around the world and contributing to major commercial developments and landmark projects.

IFI, the original foundation of Rapidrop, supports the construction and fenestration industry by supplying specialists and installers with a comprehensive range of fixings, fitting tools and consumables. Over the past eighteen months, Rapidrop has entered an exciting new phase of growth, welcoming a new CEO and Chairman alongside significant investment and long-term expansion plans. This includes new storage facilities in the UAE, increased European capacity and a new product development programme to expand our range and improve availability.

Today, our teams operate across the UK, Europe, the Middle East and South Africa, supported by continued investment in our UK headquarters, including a fully refurbished modern office environment. With a collaborative culture and a growing international footprint, Rapidrop offers an exciting opportunity to contribute to a business focused on innovation, growth and protecting people and property worldwide.



**The Shard, United Kingdom**



**Mall of Istanbul, Turkey**

# Role Overview

**Location:** Peterborough with international travel

**Contract:** Permanent

**Reports to:** Head of Portfolio and Markets

As Global Marketing Manager, you will play a key role in shaping and delivering Rapidrop's global marketing strategy. Working closely with senior stakeholders across the organisation, you will lead the development and execution of integrated, multi-channel marketing plans that support business growth, strengthen customer engagement and enhance Rapidrop's reputation across international markets.

The role will oversee marketing activity across all Rapidrop brands, including IFI, ensuring a consistent global brand framework while supporting the distinct positioning and commercial objectives of each brand.

Success in this role requires a strong understanding of global markets and cultural nuances in marketing and communications, ensuring campaigns, messaging and brand activity resonate effectively with diverse international audiences.

This is an exciting opportunity for a commercially minded marketing professional who thrives in a fast-paced, collaborative environment and enjoys delivering marketing initiatives that create measurable impact. The role will also involve international travel to Rapidrop locations and key markets to support collaboration, global campaigns, trade exhibitions and business development activity.



**Agbar Tower, Spain**



**Hilton Airport, Amsterdam, Netherlands**

# Key Responsibilities

- Lead Rapidrop's global marketing strategy, aligning campaigns with commercial growth objectives
- Plan and deliver high-impact marketing campaigns across digital, events, product marketing and communications channels
- Partner with sales teams to drive lead generation and market growth across international markets
- Support product launches and new market opportunities, creating compelling marketing materials and campaigns
- Build strong relationships across global teams, ensuring marketing activity reflects regional markets and customer needs
- Manage agencies, suppliers and marketing budgets, ensuring strong ROI and effective campaign performance
- Drive innovation and continuous improvement, monitoring market trends and identifying new opportunities to strengthen Rapidrop's global brand



**Wembley Stadium, United Kingdom**

# Experience & Expertise

## Essential

- Proven experience developing and delivering strategic marketing plans and multi-channel campaigns
- Strong commercial awareness, supporting sales growth and market expansion
- Experience working with suppliers, agencies and external partners
- Experience managing budgets and reporting on marketing performance and ROI
- Excellent communication, organisation and stakeholder management skills
- Experience working in international or global markets, with an understanding of cultural differences and how marketing approaches may need to be adapted for diverse audiences

## Desirable

- Experience managing or mentoring a marketing team (internal and/or external partners).
- Experience in both B2B and B2C marketing environments.
- Experience supporting product launches and product marketing strategies.
- Familiarity with marketing performance reporting tools and campaign analytics.



VIMD Kwart, Zagreb, Croatia



Heathrow Airport, Terminal 5, United Kingdom

# Why Join Rapidrop?

Rapidrop is a growing international business with a strong reputation for quality, innovation and reliability within the global fire protection industry. As the company continues its global expansion, we are investing in our people, products and capabilities to support long-term growth.

Joining Rapidrop means becoming part of a collaborative and ambitious team, where individuals are encouraged to contribute ideas, take ownership of their work and make a meaningful impact on the business.

This is an exciting opportunity to play a role in shaping the next stage of Rapidrop's international growth, working alongside experienced colleagues across multiple markets and functions.

## What We Offer

- Competitive salary
- Company pension total 8% (Employee contributions 3% Rapidrop Global contributions 5%)
- Annual leave 20-25 days (pro rata), Christmas shutdown (up to 3 days annual leave to be kept back to facilitate this)
- Death in service benefit –4 x annual salary from day 1
- International travel opportunities
- Opportunities for professional development and career progression
- Employee Assistance Program –Access to full support services 24/7, shopping rewards, health cash plan, access to online Dr Appointments



**Galeria Korona, Poland**

# Ready To Apply?

If you are excited about the opportunity to join Rapidrop and feel your experience aligns with the role, we would love to hear from you.

## Our Recruitment Process

### 1. Apply

Please [click here to submit](#) your CV and a short supporting statement

### 2. Review

Applications are reviewed on a rolling basis and interviews may take place before the closing date, so early applications are encouraged.

### 3. Initial Conversation

Shortlisted candidates will be invited to an introductory discussion via Teams.

### 4. Interviews

Candidates progressing will attend two formal interview with key stakeholders at our Head Office in Peterborough or via Teams.

### 5. Outcome

A final decision will be made and candidates will be informed as soon as possible.



## Inclusive Recruitment

Rapidrop is committed to creating an inclusive and supportive workplace where everyone feels valued, respected and able to thrive. We welcome applications from people of all backgrounds, experiences and perspectives, recognising that diversity strengthens our teams and drives innovation.

If you require any adjustments or support at any stage of the recruitment process, please let us know. We are committed to ensuring every candidate has a fair and positive experience.

**Good luck with your application. We look forward to receiving your application and exploring how you could contribute to Rapidrop's continued growth and success.**