



## Flanged Swing Check Valve Fig. 302 PN16

### General Description

Rapidrop Fig. 302 PN16 is a rubber faced, flanged swing type check valve that allows water flow in one direction only. A hinged clapper remains open with water flowing in one direction, and automatically closes when flow stops preventing back flow. Removable cover allows easy access for inspection and maintenance.

### Applications

Potable water, sewage disposal, water distribution service & feed lines, irrigation and fire protection pipe systems

### Connections

PN16 Flange to BS EN 1092-2:1997  
PN25 Flange available on request

### Maximum Working Pressure

16.0 bar (232 psi) FM Approved  
20.7 bar (300 psi) UL Listed  
25.0 bar (362 psi) LPCB & CNBOP Certificates

### Temperature Range

0°C to 80°C (32°F to 176°F)

### Coating

Fusion Bonded Epoxy Coating  
In accordance with ANSI / AWWA C550

### Approvals

FM and WRAS Approved, UL Listed, LPCB and CNBOP Certificates

### Installation

The valve must be installed with the direction arrow on the body in line with the direction of the flow in the pipeline. Rapidrop swing check valves can be installed horizontally or vertically. For vertical pipe work the flow direction should be upwards only. When installed horizontally the cover must be facing up. Large valves are provided with lifting eye bolt, which should be used to manoeuvre the valve.

**Note:** Check valves can be compromised by excessively turbulent water flow, which can lead to product damage. To minimize this risk, it's important to install check valves at a sufficient distance from sources of turbulence such as pumps, elbows, tee's, expanders, reducers, or similar components. Best practices in piping recommend placing the valve at least five times the pipe's diameter away from these components.

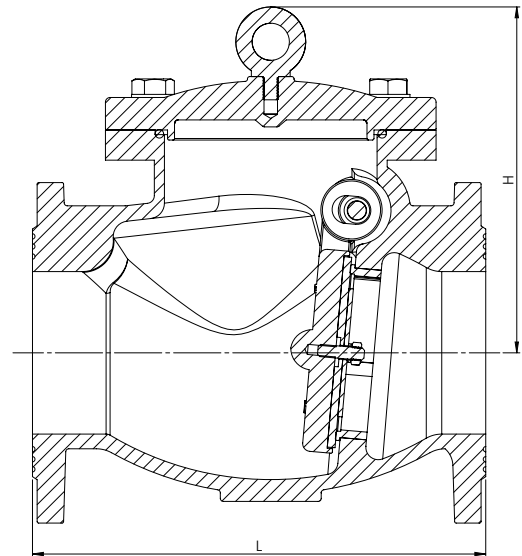

### Dimensions

Size		Dimensions (mm)		Weight (Kg)	Product Ordering Code
mm	inch	L	H		
DN50	2"	203	133	13.9	RD302CV050
DN65	2 1/2"	216	150	16.4	RD302CV065
DN80	3"	241	160	19.2	RD302CV080
DN100	4"	292	218	27.3	RD302CV100
DN150	6"	356	290	47.9	RD302CV150
DN200	8"	495	330	71.2	RD302CV200
DN250	10"	622	350	118.6	RD302CV250
DN300	12"	698	376	171.8	RD302CV300

# Flanged Swing Check Valve

## Fig. 302 PN16

### Maintenance

1. Notify any authority having jurisdiction and all personnel who may be affected prior to commencing inspection.
2. Close water supply, isolate and completely drain the valve.
3. Unscrew the bolts (3) and remove the cover (2).
4. Inspect internal parts, ensure correct operation and replace damaged parts.

- a. Seat ring (7)
- b. Cover and cover O-ring (2&6)
- c. Clapper assembly, gasket and hinge pin (8-14)

Change the clapper gasket:

- i. Remove the clapper assembly from the valve body

Unscrew one of the hinge plugs (16) from the valve body (1) and carefully remove the hinge pin (8), both hinge bushes (9) and the clapper assembly (10-14) from the valve body.

- ii. Change the clapper gasket if necessary

Remove the nut (14), the spring washer (13) and the retaining disk (12)

Replace the gasket (11) with a new one.

Reassemble in reverse order.

- iii. Reinstall clapper assembly

Insert the bushes (9) in the slots of the clapper arm (10) and carefully position the assembly inside the valve body (1) with the clapper gasket (11) facing the opposite direction of the flow arrow.

Line up the holes of the hinge plug (16) and the valve body (1) and insert the hinge pin (8).

Screw the hinge plug (16) into the valve body (1).

Ensure that the clapper assembly (10-14) moves freely.

5. Make sure all jointing faces are clean.
6. Carefully position cover ensuring O-ring (6) is not displaced.
7. Refit bolts (3) and tighten evenly.

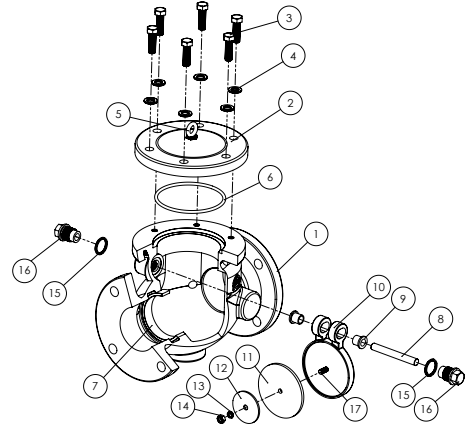

### Material Specification

No	Description	Material
1	Valve Body	Ductile Iron 65-45-12
2	Cover	Ductile Iron 65-45-12
3	Bolt	Carbon Steel Zinc Plated
4	Washer	Carbon Steel Zinc Plated
5	Eye Bolt *	Carbon Steel Zinc Plated
6	O-ring	NBR /EPDM
7	Seat Ring	Bronze C83600
8	Hinge Pin	SS304
9	Hinge Bushing	Brass C36000
10	Clapper Arm	Ductile Iron 65-45-12
11	Clapper Gasket	EPDM
12	Retaining Disc	Ductile Iron 65-45-12
13	Spring Washer	SS316
14	Nut	SS316
15	Washer	Nylon
16	Hinge Plug	Carbon Steel Zinc Plated
17	Stud	SS316

\*DN100 /4" and above

### Important Installation Information

- Rapidrop Figure 302 PN16 swing check valve must only be installed by a competent person in accordance with requirements of the local authority having jurisdiction. Deviations from these standards will invalidate warranty.
- It is the responsibility of the installing contractor to include a copy of this document in the sprinkler system installation, operating and maintenance manual.
- Alterations to Rapidrop products will void any warranty.
- Figure 302 PN16 swing check valve should be inspected and maintained during routine sprinkler system inspections by a competent person in accordance with national codes/requirements.
- Failure to follow these instructions could cause improper operation, resulting in personal injury and/or property damage.
- For further details and technical support please contact your Rapidrop sales representative.