



Priority Demand Valve

Fig. PDV-02V2

BS9251: 2014

Product Description

Rapidrop's innovative electrically driven Priority Demand valve for use with mains water supply or stored water supply residential sprinkler systems.

Designed to meet BS 9251: 2014 - Valve for isolating domestic supply in the event of sprinkler activation.

Upon activation of a flow switch / relay or tank low level switch (if installed) the valve will automatically close the domestic supply allowing all water to flow to the sprinkler system. The PDV will automatically open once the switch/ relay reset themselves

The priority demand valve is available in ball or butterfly type body (depending on connection) attached to a specific actuator (dependant on size) The appropriate PDV control box will need to be ordered separately.

The priority demand valve is available in two different configurations:

- Single PDV - Used in systems designed with a single priority demand valve

- Multiple PDV - Used in systems designed with multiple priority demand valves. Up to 25 PDVs can be simultaneously activated through a single flow switch/ alarm relay or tank low level switch



Features

Ball Valve

- Full Bore
- WRAS approved

Butterfly valve

- Stainless steel disc, EPDM liner
- Epoxy coated ductile iron body
- WRAS approved

Actuator

- Failsafe close operation (operated by an internal replaceable lithium-Ion battery)
- End of travel relay switch for valve positioning
- Visual LED indicator for positional identification
- Maximum Allowable 'Stem Torque' to protect valve
- External GSA Connectors (For RAS actuator, M20 Glands for RAM/ RAL actuator)
- IP67 Rated Actuator
- Maximum of 5W power consumption (24VDC)

Working Pressure

Max. Working Pressure 16bar (232 psi)
(Higher pressure range available on request)

Working Temperature Range

0°C to 70°C (14°F to 158°F)

Connections

Ball valve (DN25 to DN50)

- BSP female thread according to ISO 228/1

Butterfly valve (DN50 to DN200)

- Semi lug wafer pattern to suit PN16 Flange according to BS EN 1092 and Table D/E flanges according to BS 10

Operation

Rapidrop Priority demand valve is a power to open, power to close valve. In the event of power loss the valve will failsafe to the closed position.



Priority Demand Valve Fig. PDV-02V2

BS9251: 2014

Ball Valve Dimensions

Sizes		Dimensions (mm)				Flow Rate (KV)
mm	Inch	A	B	C	D	
DN25	1"	83	140	150	170	43
DN32	1 1/4"	94	140	150	175	89
DN40	1 1/2"	102	140	150	187	230
DN50	2"	124	140	150	194	265

WRAS approval for valve body owned by Brandoni S.P.A

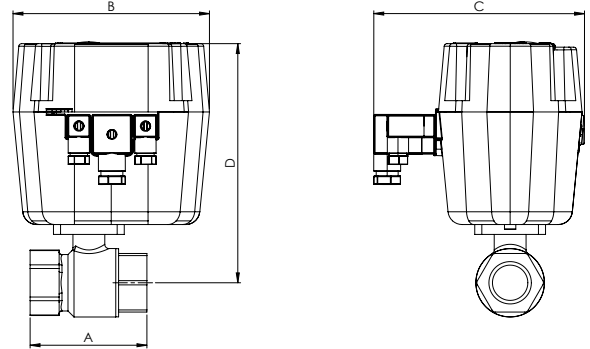

Butterfly Valve Dimensions

Sizes		Dimensions (mm)					
mm	Inch	A	B	C	D	E	F
DN50	2"	43	140	150	255	62	89
DN65	2 1/2"	46	140	150	265	69	102
DN80	3"	46	203	206	334	90	118
DN100	4"	52	203	206	354	106	150
DN125	5"	56	203	206	374	119	174
DN150	6"	56	*	*	*	133	205
DN200	8"	60	*	*	*	166	260

WRAS approval for valve body owned by Brandoni S.P.A

* Contact Rapidrop for dimensions

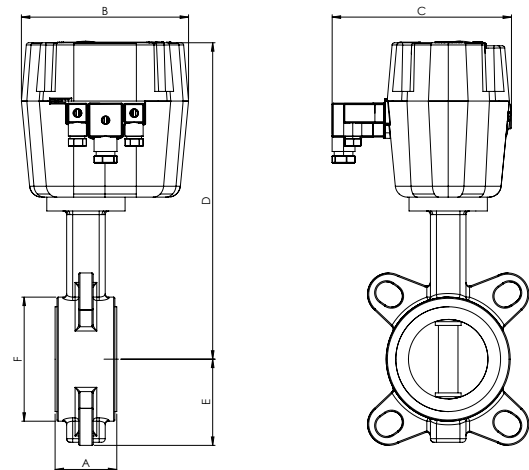

Single PDV System Ordering Codes

Sizes		Isolation Valve	Actuator Model	Ordering Codes
mm	Inch			
DN25	1"	Ball Valve	RAS	RDPDV-02-025BLV2
DN32	1 1/4"	Ball Valve	RAS	RDPDV-02-032BLV2
DN40	1 1/2"	Ball Valve	RAS	RDPDV-02-040BLV2
DN50	2"	Ball Valve	RAS	RDPDV-02-050BLV2
DN50	2"	Butterfly Valve	RAS	RDPDV-02-050V2
DN65	2 1/2"	Butterfly Valve	RAS	RDPDV-02-065V2
DN80	3"	Butterfly Valve	RAM	RDPDV-02-080V2
DN100	4"	Butterfly Valve	RAM	RDPDV-02-100V2
DN125	5"	Butterfly Valve	RAM	RDPDV-02-125V2
DN150	6"	Butterfly Valve	RAM+Gearbox	RDPDV-02-150V2
DN200	8"	Butterfly Valve	RAM+Gearbox	RDPDV-02-200V2

The above ordering codes include 1x electrically actuated isolation valve only.
Appropriate control box need to be ordered separately.

Multiple PDV System Ordering Codes

Sizes		Isolation Valve	Actuator Model	Ordering Codes
mm	Inch			
DN25	1"	Ball Valve	RAS	RDPDV-02-025BLV2SM
DN32	1 1/4"	Ball Valve	RAS	RDPDV-02-032BLV2SM
DN40	1 1/2"	Ball Valve	RAS	RDPDV-02-040BLV2SM
DN50	2"	Ball Valve	RAS	RDPDV-02-050BLV2SM
DN50	2"	Butterfly Valve	RAS	RDPDV-02-050V2SM
DN65	2 1/2"	Butterfly Valve	RAS	RDPDV-02-065V2SM
DN80	3"	Butterfly Valve	RAM	RDPDV-02-080V2SM
DN100	4"	Butterfly Valve	RAM	RDPDV-02-100V2SM
DN125	5"	Butterfly Valve	RAM	RDPDV-02-125V2SM
DN150	6"	Butterfly Valve	RAM+Gearbox	RDPDV-02-150V2SM
DN200	8"	Butterfly Valve	RAM+Gearbox	RDPDV-02-200V2SM

The above ordering codes include 1x electrically actuated isolation valve only.
Appropriate power supply unit and control box need to be ordered separately.

Priority Demand Valve

Fig. PDV-02V2

BS9251: 2014

Specifications

Valve Size/ Actuator model	DN25 - DN65 (1" - 2 1/2") RAS Actuator	DN080 - DN125 (3" - 5") RAM Actuator	DN150 - DN200 (6" - 8") RAM Actuator (With gearbox attachment)
Working Time 0-90°	8 Seconds	4 Seconds	16 Seconds
Current	0.55A	0.55A	0.55A
Power Supply	12-30V	12-30V	12-30V
IP Rating	IP67	IP67	IP67
End of Travel Relays	300VAC/900mA - 30VDC	250VAC/5A - 30VDC	250VAC/5A - 30VDC
Ambient Temp Range	-20°C to 70°C	-20°C to 70°C	-20°C to 70°C
Manual Override	Local Buttons (Disabled as standard)	Local Buttons (Disabled as standard)	Local Buttons (Disabled as standard)
Bluetooth Control	Via Android App	Via Android App	Via Android App
Cable Entries	External GSA	2 x M20 Cable Glands	2 x M20 Cable Glands

Installation

The valve may be installed in any position and the flow may be from either direction through the valve.

1. Visually inspect the valve, make sure that the connections are clean of debris and any foreign materials.
2. Mount/connect the valve to the pipework (Valve in the closed position) **Note for butterfly valve bodies do not over torque the flange. This may distort the rubber seal.**
3. Wire the valve following the below sequence;

RAS - Remove the lid by undoing the 4 bolts using a 3mm allen key. **Connect the battery** within the actuator using the nylon male/female plug. Re-assemble the lid cover. Undo the centre GSA screw using a Phillips or flat-head screwdriver. Wire as per wiring diagram. Re-assemble the GSA plug onto the actuator.

RAM - Remove the lid by undoing the 6 bolts using a 3mm allen key. **Connect the battery** within the actuator using the nylon male/female plug. Disconnect the terminal block and wire as per wiring diagram. Re-assemble the lid.

4. Functional test the operation of the valve via the flow switch or relay. The solid green LED will indicate the valve is in the open position. The solid red LED will indicate the valve is in the closed position.
5. The internal battery is disconnected for storage/travel and to prevent detriment to the battery. During commissioning or after, if the PDV is going to be unpowered for a prolonged period (Over 1 year RAS & over 1 month RAM) we recommend disconnecting the battery to secure its longevity.

Note: The PDV should be wired by a qualified electrician. Follow relevant safety procedures when handling the circuit board

Connection of battery

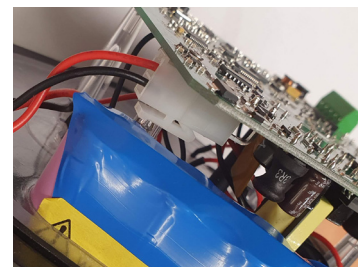

RAS - GSA Connector



RAM terminal block

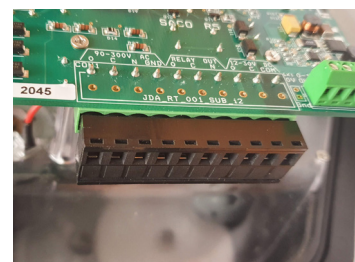



Priority Demand Valve Fig. PDV-02V2

BS9251: 2014

Control Box - Single PDV Systems

Upon activation of a flow switch/alarm relay or tank low level switch (if installed in the system) the PDV will automatically close. It will re-open once the flow switch/alarm or tank low level switch reset themselves.

Features

- Metal IP66 wall mounted enclosure with external mounting brackets
- Internal DIN rail mount terminals for connection of:
 - Flow Switch/Alarm Relay
 - Power supply connection to PDV
- Power supply requirements: 230V AC connected to a 3A fused spur

RDPDVBOX



Description	Ordering Code
Single PDV Control Box	RDPDVBOX

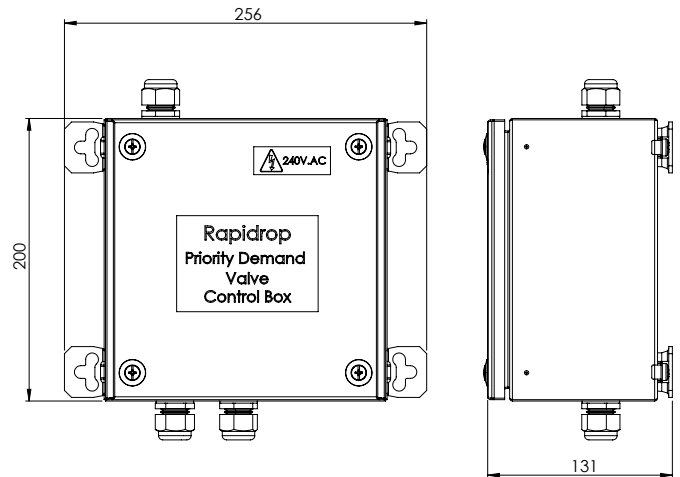

Priority Demand Valve

Fig. PDV-02V2

BS9251: 2014

Single PDV Wiring Diagram

'RDPDVBOX'

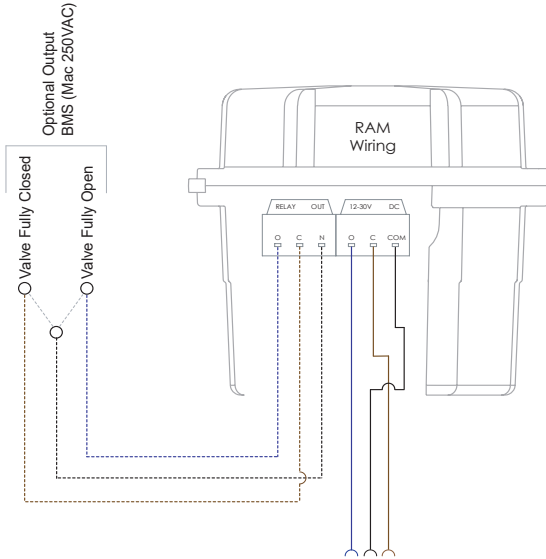

RAM Wiring			
Actuator	Control Box	PDV Open	PDV Closed
C	24		+24V
O	25	+24V	
COM	26		-24V

Note: Use the 12-30V DC Terminal within the isolation valve

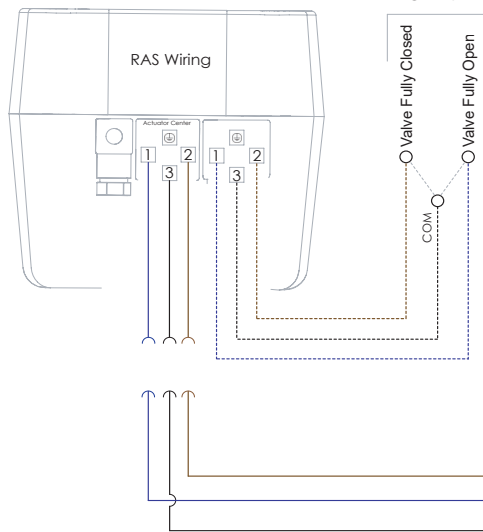

RAS Wiring			
Actuator Center	Control Box	PDV Open	PDV Closed
2	24		+24V
1	25	+24V	
3	26		-24V

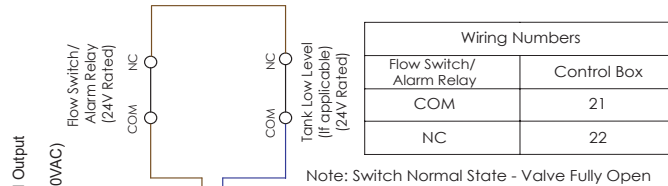

Note: Switch Normal State - Valve Fully Open

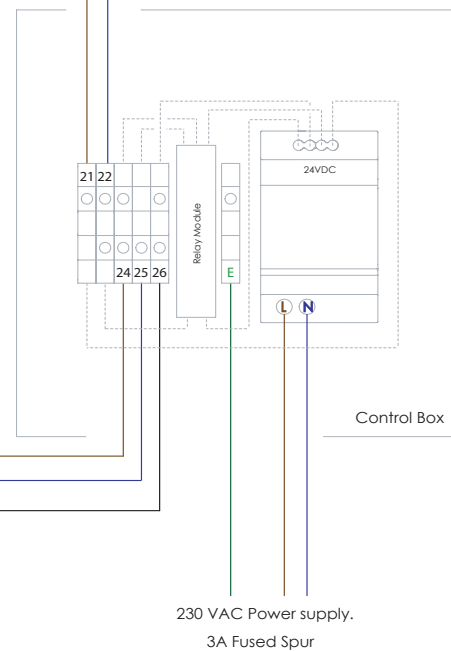

Priority Demand Valve

Fig. PDV-02V2

BS9251: 2014

Control Boxes - Multiple PDV Systems

Upon activation of a flow switch/alarm relay or tank low level switch (if installed in the system) all connected PDV will automatically close. They will re-open once the flow switch/alarm or tank low level switch reset themselves.

Rapidrop's priority demand valve can be linked to activate up to 25 valves simultaneously through a single flow switch/alarm relay.

One 'multiple priority demand valve power supply unit' can power up to 7 'multiple priority demand valves'

One 'Multiple priority demand valve control box' can control up to 25 Priority demand valves

Upon power loss to either of the PSU or control box. The priority demand valve will fail safe to the closed position.

For linking more than 25 priority demand valves contact Rapidrop representative for more information.

Follow the installation process as per page 3 and wire as per the diagram below.

Features

- Metal IP66 wall mounted enclosure
- Internal DIN rail mount terminals for connection of:
 - Flow Switch/ Alarm Relay
 - Power supply connection to PDV (PSU)
 - Power supply Circuit for connection to PDV (Control Box)
- Power supply requirements: 230V AC connected to a 3A fused spur

RDPDV-LCMU

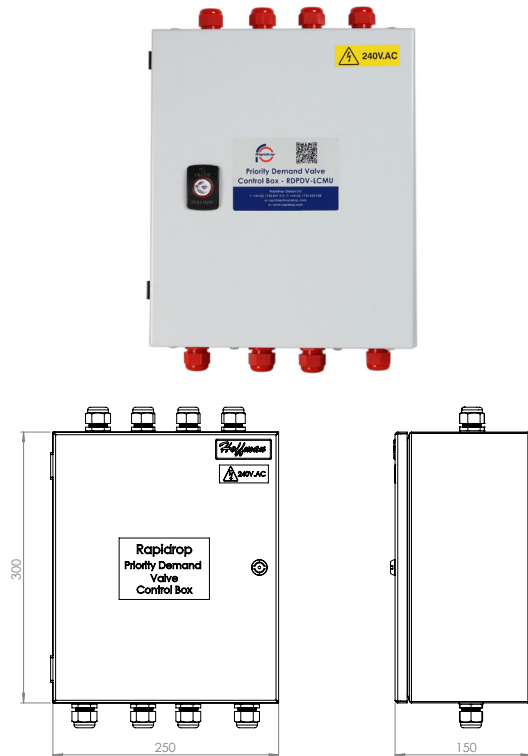

RDPDV-PSU

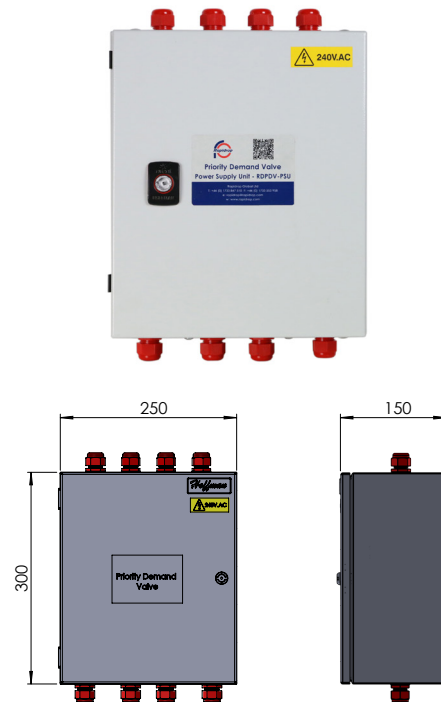

Description	Ordering Codes
Multiple Priority Demand Valve Power Supply Unit	RDPDV-PSU
Multiple Priority Demand Valve Control Box	RDPDV-LCMU



Priority Demand Valve

Fig. PDV-02V2

BS9251: 2014

Multiple PDV Wiring Diagram

'RDPDV-LCMU with RDPDV-PSU'

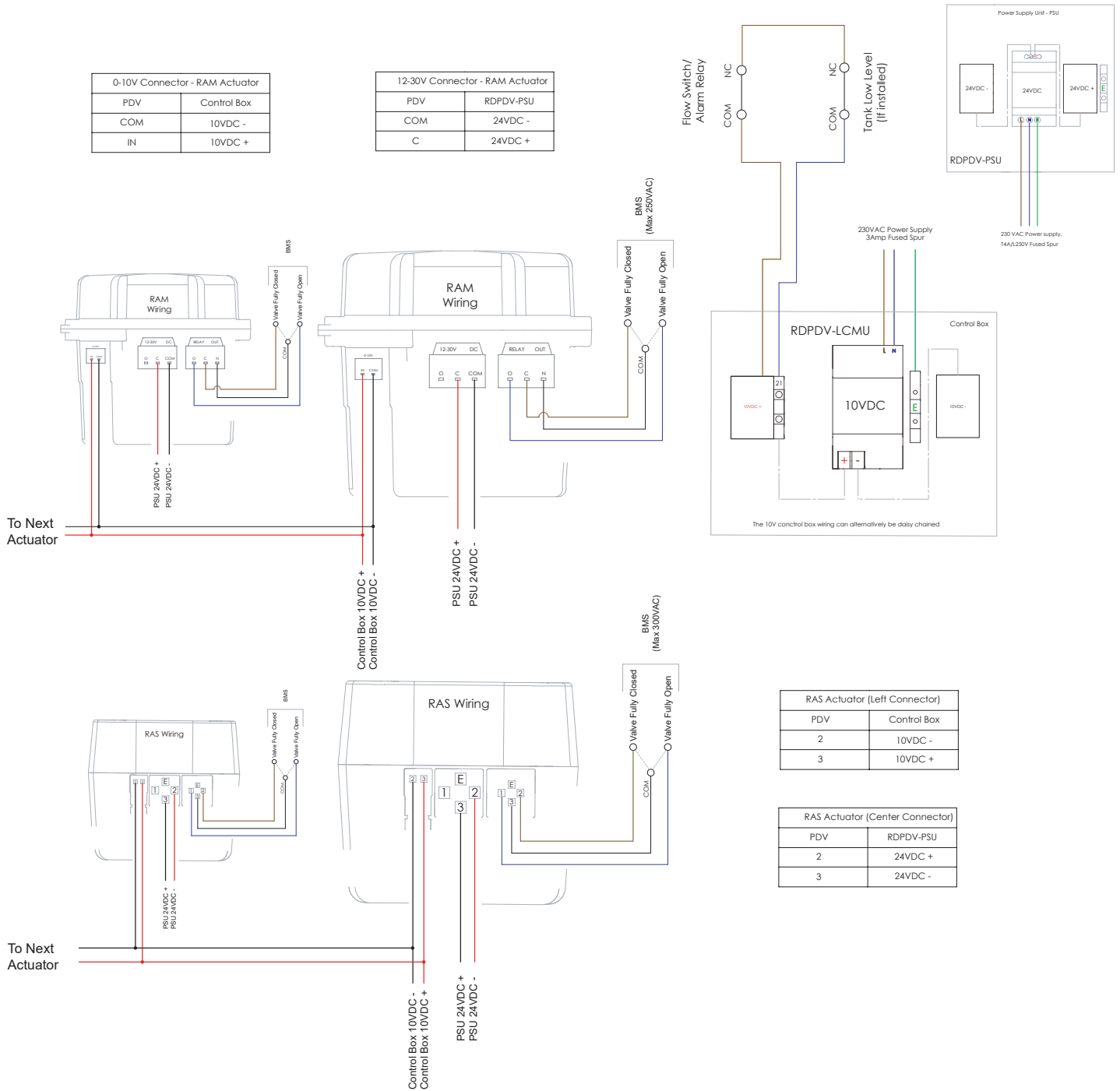

Priority Demand Valve Fig. PDV-02V2

BS9251: 2014

Operation/ Function Guide

RAS Actuator Model DN25-DN50 (1" - 2 1/2")

LED Function Table

LED	LED Colour	LED Function
A - Bluetooth	Solid Blue	Paired
	Off	Asleep
	Flashing Blue	Awake Bluetooth not paired
B - Charging	Solid Blue	Charging
	Off	Charged
C - Direction/ Operation	Green Solid	Open
	Green Flashing	Opening
	Red Solid	Closed
	Red Flashing	Closing
	Slow Orange Flash	Manual Mode
	Rapid Orange Flash	Over Torque

Note: The touchpad button text is not related to the LED function (D)

RAS Actuator
LED Illustration

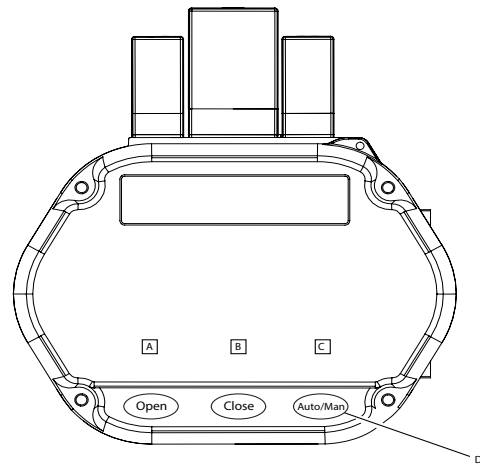

RAM Actuator Model DN80-DN200 (3" - 8")

LED Function Table

Illustration Number	LED Colour	LED Function
1	Rotating Green	Valve Opening
2	Flashing Green	Connected to Bluetooth
3	Solid Green	Valve Open
4	Rotating Red	Valve Closing
5	Solid Red	Valve Closed
6	Flashing Red	Valve is in Manual Mode
7	Flashing Amber	Valve failed to complete move in time
8	Flashing Amber	Reached Max Torque
9	Flashing Amber	Battery Voltage Low

RAM Actuator
LED Illustration

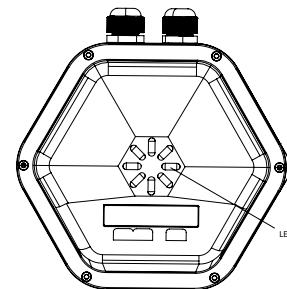
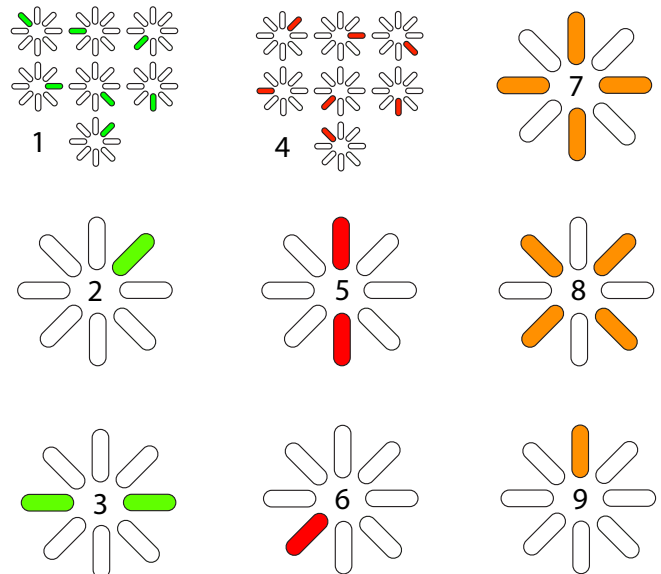



Troubleshooting guide

Issue	Cause	Corrective Action
PDV Not Powering On	Power Supply/Battery	<ul style="list-style-type: none"> • Check Battery Connected • Check Battery Voltage (refer to maintenance for correct voltage) • Check Wiring Diagram
Over torque	Over tightened flange causing the valve seat to distort or foreign body within pipe	<ul style="list-style-type: none"> • Loosen flange bolts to try to rectify valve seat distortion
Battery Low	Battery	<ul style="list-style-type: none"> • Power the PDV (this will allow the battery to charge) • Replace the battery • Charge the battery for a minimum of 1 hour (Or longer if the battery is very low)
Valve Not Functioning	Potential PCB sensor location	<ul style="list-style-type: none"> • Ensure the PCB is fixed in place as supplied • Ensure the Actuator lid is fixed in place (RAS)
Valve failed to move in time	Actuator taken longer than the pre-set time to move	<ul style="list-style-type: none"> • Contact Rapidrop to modify settings

The table above is intended as a guide. Please call Rapidrop for any queries

Care and Maintenance

The priority demand valve requires very little maintenance.

- Ensure all valve body connecting bolts are securely fastened
- Ensure the battery is fully charged, 8V (RAS), 15.8V (RAM)

An orange flashing LED light indicates the battery requires replacing or regenerating. Rapidrop recommend replacing the battery every 3 years at a minimum to prevent detriment of the system.

General control box considerations including but not limited to;

- Ensure all terminals/wires are secure
- Insulation resistance test
- Ensure all relays are correctly engaged

It is advisable to inspect and verify the operation of the unit annually or in accordance with the authority having jurisdiction.

Important information

- The installation and maintenance of the priority demand valve must only be made by qualified personnel.
- Ensure electrical installation is as per BS 9251: 2021
- Before removing any covers, always make sure the power supply to the control unit is shut off.
- Failure to follow these instructions could cause improper operation, resulting in personal injury and/or property damage.
- For further details and technical support please contact your Rapidrop sales representative.