



Wet Alarm Valve UL/FM/NFPA Trim Model B, D, E

General Description

Model B, D & E wet alarm valves are designed for use in wet pipe sprinkler installations in buildings not subject to freezing temperatures.

This type of wet alarm valve is designed to automatically initiate electric or hydraulic alarm whenever there is a flow of water to one or more sprinklers.

A variety of trim packages are available to suit the requirements of the authority having jurisdiction and a number of accessories can be supplied including straps and padlocks, pressure switches, retard chamber and water motor alarm gong.

All assemblies are hydrostatically tested to 18 Bar prior to despatch.

This valve must be installed vertically in the main supply to a wet pipe sprinkler system.

Operation

In the case of a fire the sprinkler head operates and the pressure on the system side of the clapper falls below the pressure on the supply side. The clapper lifts off the grooved seat and permits water flow from the supply to enter the system for distribution on the fire. Water also flows through the clapper seat to the alarm device via the optional retard chamber.

A pressure surge or water hammer in the supply line may increase the pressure on the supply side of the clapper, causing it to lift intermittently which may result in a false alarm.

The Wet alarm valve prevents such false alarms by two features:

- An external by-pass allows the pressure surge from the supply to bypass the alarm valve clapper. This creates an excess system pressure and thus steadies the clapper.
- Should a heavy surge unseat the clapper and allow water to flow into the alarm line, the optional Model E retard chamber comes into action, delaying the activation of the alarm. Specially designed inlet and drain orifices allow the chamber to partially drain before filling and activating the alarm device.

The retard chamber is supplied with a strainer in the supply line to prevent foreign matter from clogging the inlet orifice.

Pressure Rating

Max. Working Pressure 12 Bar (175 PSI)

Approvals

UL, FM



Models

Model	Sizes	Connection Type
Model B Flange – Flange	DN80 (3")	Flange*: - ANSI 125/150 - PN16 (hole drilling pattern)
	DN100 (4")	
	DN150 (6")	
	DN200 (8")**	
Model D Flange – Groove	DN100 (4")	Flange*: - PN16 (hole drilling pattern) Groove: - DN100 (4"): 114.3 OD - DN150 (6"): 165.1 OD (UK) - DN150 (6"): 168.3 OD - DN200 (8"): 219.1 OD
	DN150 (6")	
	DN200 (8")	
Model E Groove – Groove	DN100 (4")	Groove: - DN100 (4"): 114.3 OD - DN150 (6"): 165.1 OD (UK) - DN150 (6"): 168.3 OD
	DN150 (6")	

*All valves with flange connections are supplied with flat face flanges.

**The PN16 drilling on the top flange of the DN200 size valve is radially off set to the drilling in the bottom flange. This is required to achieve bolt clearance of the body casting and must be taken into consideration in the design of mating flanged pipe work.



Wet Alarm Valve UL/FM/NFPA Trim Model B, D, E

Wet Alarm Valve DN80(3"), DN100(4"), DN150(6")

Dimensions

Nominal Size		Dimensions (mm) ±20mm								
mm	inch	A	B	C	D	E	F	G		
								mod.B	mod.D	mod.E
DN80	3"	365	300	380	255	125	170	273	-	-
DN100	4"	400	305	370	285	130	175	225	263	286
DN150	6"	390	285	385	285	145	160	267	280	287

Weights

Nominal Size		Weight (kg) approx.					
mm	inch	Body			Body with Trim		
		mod.B	mod.D	mod.E	mod.B	mod.D	mod.E
DN80	3"	23	-	-	30	-	-
DN100	4"	23.5	23	19	31	30	26
DN150	6"	35.5	29.5	23	42.5	36.5	30

Trim Components

Part No.	Description
1	Valve Body
2	Drain Gate Valve
3	Test Ball Valve (Normally Closed)
4	Alarm Line Ball Valve (Normally Open)
5	Check Valve
6	Drip Union
7	System Pressure Gauge
8	Supply Pressure Gauge
9	Alarm Pressure Switch *
10	Retard Chamber *
11	Water Motor Alarm Gong *

*Optional extras

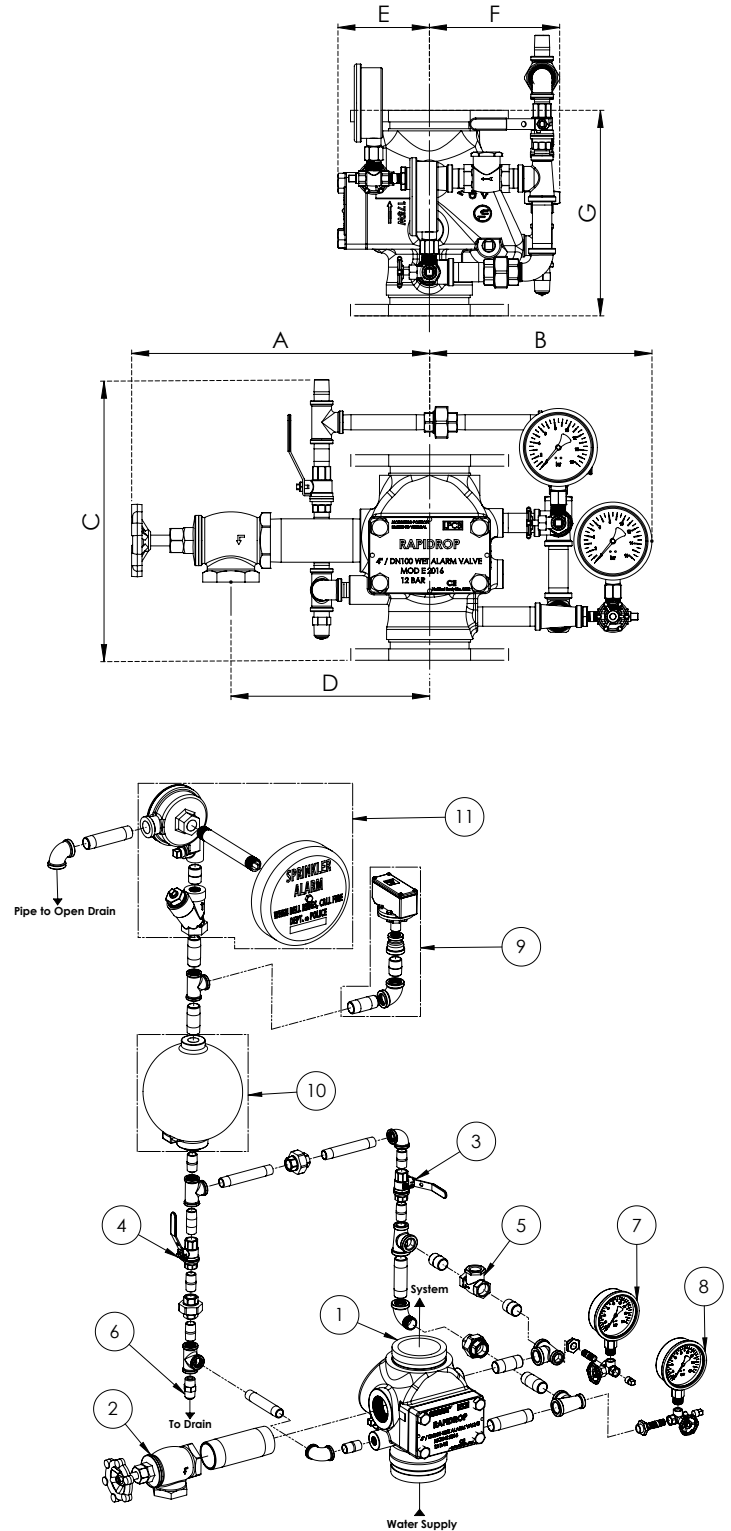



Wet Alarm Valve UL/FM/NFPA Trim Model B, D, E

Wet Alarm Valve DN200 (8")

Dimensions

Nominal Size		Dimensions (mm) ±20mm								
mm	inch	A	B	C	D	E	F	G		
								mod.B	mod.D	mod.E
DN200	8"	405	170	465	280	230	185	298	335	-

Weights

Nominal Size		Weight (kg) approx.					
mm	inch	Body			Body with Trim		
		mod.B	mod.D	mod.E	mod.B	mod.D	mod.E
DN200	8"	60	57	-	67	64	-

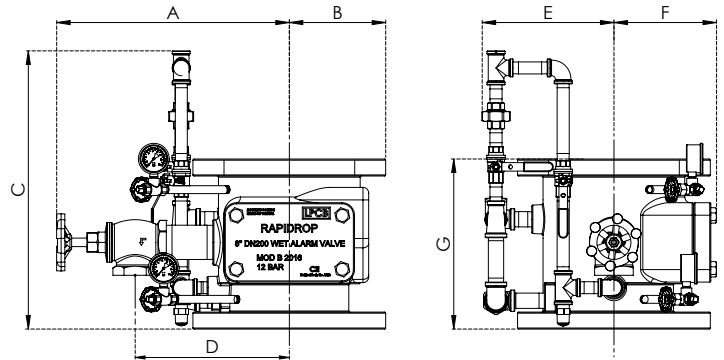

Trim Components

Part No.	Description
1	Valve Body
2	Drain Gate Valve
3	Test Ball Valve (Normally Closed)
4	Alarm Line Ball Valve (Normally Open)
5	Check Valve
6	Drip Union
7	System Pressure Gauge
8	Supply Pressure Gauge
9	Alarm Pressure Switch *
10	Retard Chamber *
11	Water Motor Alarm Gong *

*Optional extras

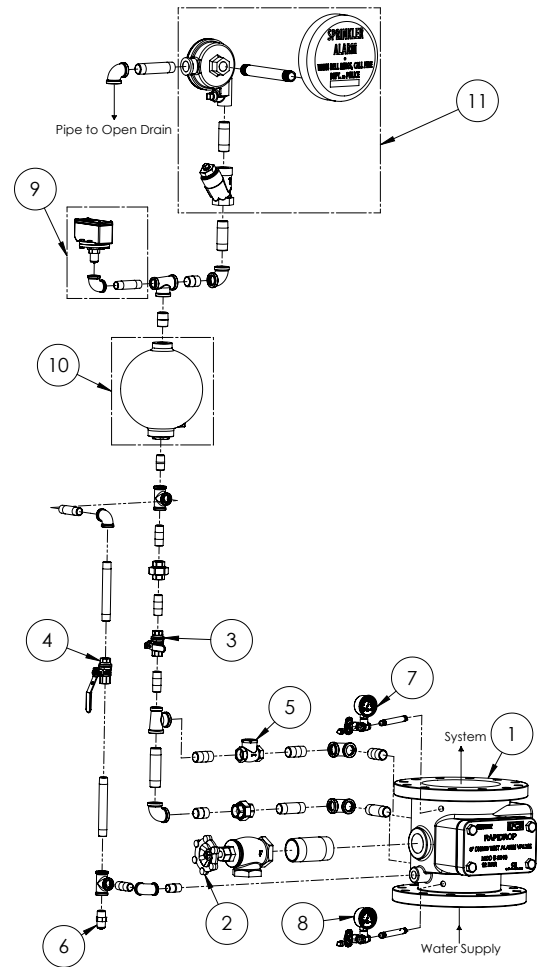

Wet Alarm Valve UL/FM/NFPA Trim Model B, D, E

DN80, DN100, DN150

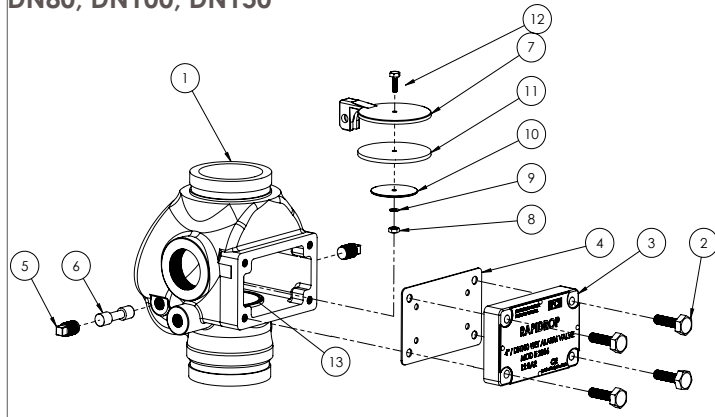

DN200

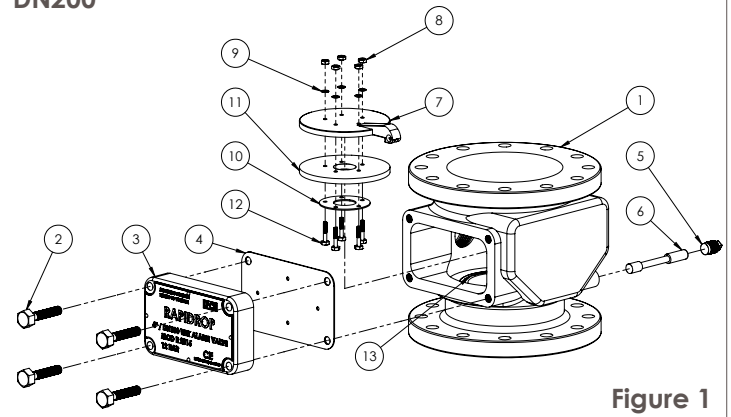

Figure 1

Maintenance (See Figure 1&2)

The wet alarm valve requires very little maintenance and there is no need for any adjustments. The system pressure should be equal to or higher than the supply pressure. It is recommended to regularly examine the wet alarm valve to ensure reliability.

Inspection of the valve should be as follows:

1. Notify the Fire Service, Insurance Provider and other centres requiring notification prior to commencing inspection.
2. Remove any padlocks and straps.
3. Close supply stop valve and open the main drain valve.
4. After the system is fully drained, remove the cover plate (3).
5. Remove the clapper shaft retaining plug(s) (5) and the clapper shaft (6).
6. Clean thoroughly removing any accumulated deposits. Inspect the clapper gasket (11).
7. If the clapper gasket (11) is worn or damaged, unscrew the clapper nut (8) and disassemble clapper components (7-12).
8. Replace damaged components with genuine replacement parts, and reassemble clapper as shown in Figure 1.
9. Inspect the clapper seat ring (13) inside the valve body for lodgement of dirt, bruising or scoring. Clean thoroughly if necessary.
10. A damaged clapper seat ring (13) can be carefully polished using lapping compound. If the damage is extensive then a complete new valve should be fitted.
11. After the inspection and replacement of parts, reinstall the clapper assembly (7-12) and fix it with the clapper shaft (6).
12. Lock the clapper shaft (6) with clapper shaft retaining plug(s) (5) and reinstall cover plate gasket (4) and cover plate(3).
13. Remove swing clapper from the check valve on the by-pass line, and check condition of the clapper and the seat.
14. Replace complete unit if damaged.
15. When every part is reinstalled close the main drain valve and reset the valve as described in 'Procedure after a fire'.

Valve Components

No	Description	Qty. DN80 DN100 DN150	Qty. DN200
1	Valve Body	1	1
2	Cover Plate Bolt	4	4
3	Cover Plate	1	1
4	Cover Plate Gasket	1	1
5	Clapper Shaft Retaining Plug	2	1
6	Clapper Shaft	1	1
7	Clapper	1	1
8	Clapper Nut	1	5
9	Clapper Bolt Lock Washer	1	5
10	Clapper Retainer	1	1
11	Clapper Gasket	1	1
12	Clapper Bolt	4	5
13	Clapper Seat Ring	1	1

Wet Alarm Valve UL/FM/NFPA Trim Model B, D, E

DN80, DN100, DN150

DN200

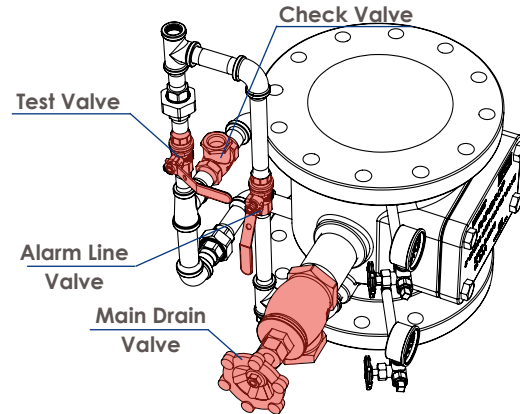
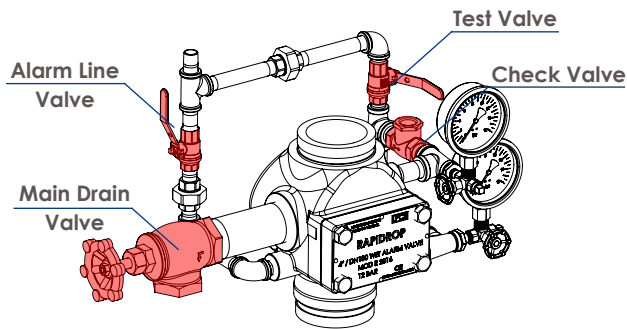

Figure 2

Procedure After a Fire

(See Figure 2)

1. Remove any padlocks and straps.
2. Close the supply stop valve.
3. If a sprinkler pump is in use, turn it off.
4. Open the main drain valve to drain the system.
5. Replace activated sprinklers with new of equivalent specification.
6. Close main drain valve.
7. Make sure both Test and alarm line valves are closed.
8. Partially open the supply stop valve.
9. Restart the sprinkler pump (If pumped water supply).
10. Wait until the supply pressure equals the system pressure.
11. Open supply stop valve fully.
12. Open the alarm line valve.
13. Conduct alarm test as described in 'Weekly test'.
14. Replace all padlocks and straps where fitted.
15. Reorder spare sprinklers to equivalent specification.

Weekly Test Procedure

(See Figure 2)

1. Notify the Fire Service, Insurance Provider and other centres requiring notification prior to operating the alarm.
2. Record supply pressure and system pressure.
3. Remove any padlocks and straps.
4. Open test valve and ensure that the alarm is activated. (The test and drain valve shall not be used in lieu of the inspector's test connection for the testing of the entire wet piping system.)
5. After completing the test, close the test valve.
6. Check supply pressure is equal to the system pressure.
7. Replace all padlocks and straps where fitted.



Wet Alarm Valve UL/FM/NFPA Trim Model B, D, E

Pressure Loss Graph

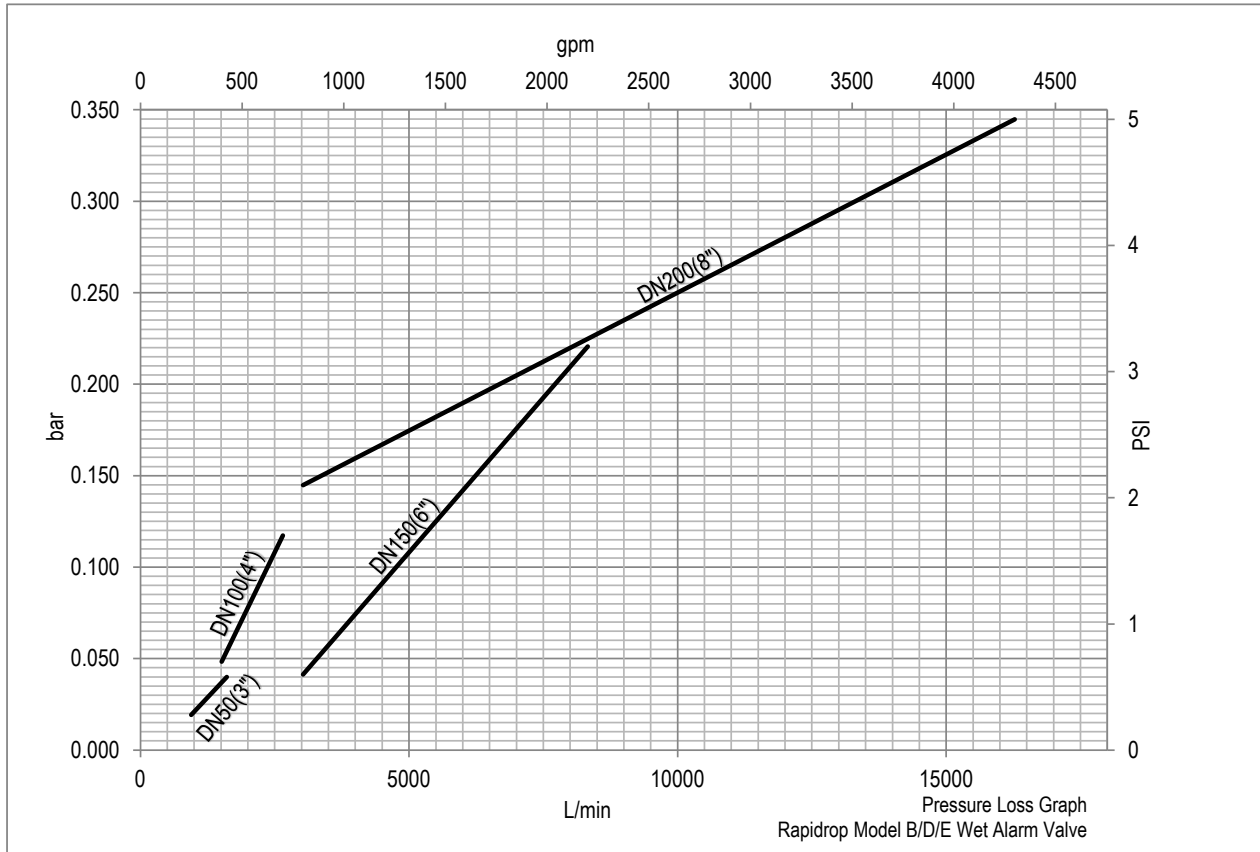

Important Installation Information

- Rapidrop Model B, D, E wet alarm valves must only be installed by a competent person in accordance with requirements of the local authority having jurisdiction. Deviations from these standards will invalidate warranty.
- It is the responsibility of the installing contractor to include a copy of this document in the sprinkler system installation, operating and maintenance manual.
- Alterations to Rapidrop products will void any warranty.
- Model B, D, E wet alarm valve should be inspected and maintained during routine sprinkler system inspections by a competent person in accordance with national codes/requirements.
- Failure to follow these instructions could cause improper operation, resulting in personal injury and/or property damage.
- For further details and technical support please contact your Rapidrop sales representative.