



Dry Pipe Valve Model A, B & E

General Description

Dry Pipe Valve is essentially a differential check valve. The bronze clapper carries two rubber gaskets. The larger (air) gasket is rubber and seats against pure tin. The smaller (water) gasket is a specially designed rubber disc, which also seats on pure tin. These seats are proportioned so that 1 pound (.454 kg) of air pressure will hold back approximately 6 pounds (2.72kg) of water pressure.

When the air pressure on the surface of the priming water is relieved by the opening of a sprinkler, the upward pressure of the water underneath the water gasket causes the clapper to lift, the chamber instantly fills and sounds the alarm. The water pressure acting on the entire surface of the clapper pushes it over to the wide open position and thus leaves a passage for the water to the sprinkler system.

Working Pressure

Max. Working Pressure 12bar (175psi)

Approvals

FM Approved

UL Listed

Resetting Dry Pipe Valve

1. Close main controlling valve or post indicator to shut off water supply to sprinkler system.
2. Open valve 1 to drain sprinkler system.
3. Gong and electric valve may be shut off by closing valve 2.
4. Vent sprinkler system by opening 3/4" (19.05mm) inspector's test valve which is normally located at the top.
5. After system is thoroughly drained, remove cover plate 3 for resetting dry valve.
6. Raise clapper off seat and scoop out any scale or solid particles found in intermediate chamber, in the bottom of the valve air and water seats. Using a clean piece of cloth wipe the surface of the rubber seats on the swinging clapper, also the tin seats in the valve. Never apply grease, tallow, or any other substance to water or air seat.
7. Let bronze clapper down on its seat making sure that the rubber air ring presses evenly all around the air seat.
8. Put on cover plate 3 making sure that gasket is in good condition. Replace nuts and tighten evenly, all around.
9. Drip valves are found at low points (if any) on sprinkler piping. They would not be drained by previous operation - open these valves for draining after removing plugs and close when water stops running
10. Close 3/4" (19.05mm) inspector's test valve, previously opened to vent system.
11. Replace sprinklers fused by fire.



12. Prime by opening valve 4 and slowly pour water into priming cup 5 until priming level is even with the cup. Remove plug 7 in valve 6 which is normally open; after water stops running replace plug 7 and close valve 4 tightly. Water must not be allowed to stand above the priming water level.

13. Open valve 8 and pump air pressure into the system. When ten pounds (4.536 kg) pressure has been built up, open drip valve again to force water from low points of system. Close drip valves tightly and plug.

14. Pump the correct air pressure into the sprinkler system, then close valve 8 tightly. Make sure there is no leakage of priming water by the rubber air seat into drip cut 10 by observing automatic drain valve 9.

Note: Never allow air pressure to drop below minimum limit, to safeguard against accidental tripping of dry valve. Air pressure required for sprinkler system should be calculated at approximately one (1) PSI of air for every six (6) PSI of water pressure. The air pressure should be maintained at approximately twenty (20) PSI above calculated air pressure, per NFPA-13.

15. Partly close valve 1- then open main controlling valve slowly, until water is heard flowing through drain valve 1, then close tightly and open controlling valve fully and seal.

16. To check water seat inside the dry pipe valve, look at the automatic drain valve 9, and make sure that no water is leaking into the drip cup 10.

17. Open automatic drain valve 9 to be sure no water remains in pipe to alarm devices, then close.

18. Valve 2 should now be opened.



Dry Pipe Valve Model A, B & E

Inspection and Maintenance

A minimum of two people should be familiar with the sprinkler system but at least one should be held responsible for its proper maintenance

1. Test main riser for water to make sure dry pipe valve is not water columned. Water should be up to but not above the level of valve
2. Close main control valve. Open main drain valve 1.
3. Close valve 6 and remove plug 7. Open 6 to drain water which is above the level of this valve. Replace plug 7 and open valve 6. Check air pressure according to NFPA-13. Close drain valve 1 and the open main control valve.
4. Air pressure must be maintained and checked weekly under normal conditions. During freezing weather it should be checked daily. Check valve 8 in the fall before freezing weather sets in to assure a tight seat.
5. Alarm devices may be tested occasionally without tripping the dry pipe valve by opening valve 11 if weather allows.
6. Drip valves or drum drips should be drained before freezing weather sets in and occasionally during winter.

Note: We also recommend at least an annual inspection by qualified inspectors of the complete fire protection system. Many times defects may be detected during inspection and repairs made before they develop into major troubles might mean the protection would be off in your plant for several days.

Parts List

Item No.	Description
1	Body
2	Cover Gasket
3	Heavy Hex. Nut
4	Cover Plate Stud 3/4"
5	Cover
6	Air Seat
7	Water Seat
8	Latch
9	Clapper Arm Assembly
10	Clapper Assembly
11	Arm Hinge Pin Plug
12	Asbestos Gasket
13	Arm Pin Bushing
14	Arm Hinge Pin
15	Cotter Pin Brass
16	Clapper Pin Bushing
17	Latch Pin Bushing
18	Latch Pin
19	Clapper Hinge Pin
20	Machine Screw
21	Hex Cap Screw
22	Water Seat Disc
23	Water Seat Gasket
24	Air Seat Retainer
25	Air Seat Gasket
26	Lock Washer

Size	Connection		Face to Face	Working Pressure	Weight	Approvals		
	mm	inch				UL	FM	
DN80		3"	Flange x Flange	375mm (14 3/4")	12 bar (175 psi)	56 kg (125lbs)	X	✓
DN100		4"	Flange x Groove	378mm (14 7/8")	12 bar (175 psi)	56 kg (125lbs)	✓	✓
DN100		4"	Groove x Groove	387mm (15 1/4")	12 bar (175 psi)	50 kg (112lbs)	✓	✓
DN150		6"	Flange x Groove	495mm (19 1/2")	12 bar (175 psi)	136 kg (300lbs)	✓	✓

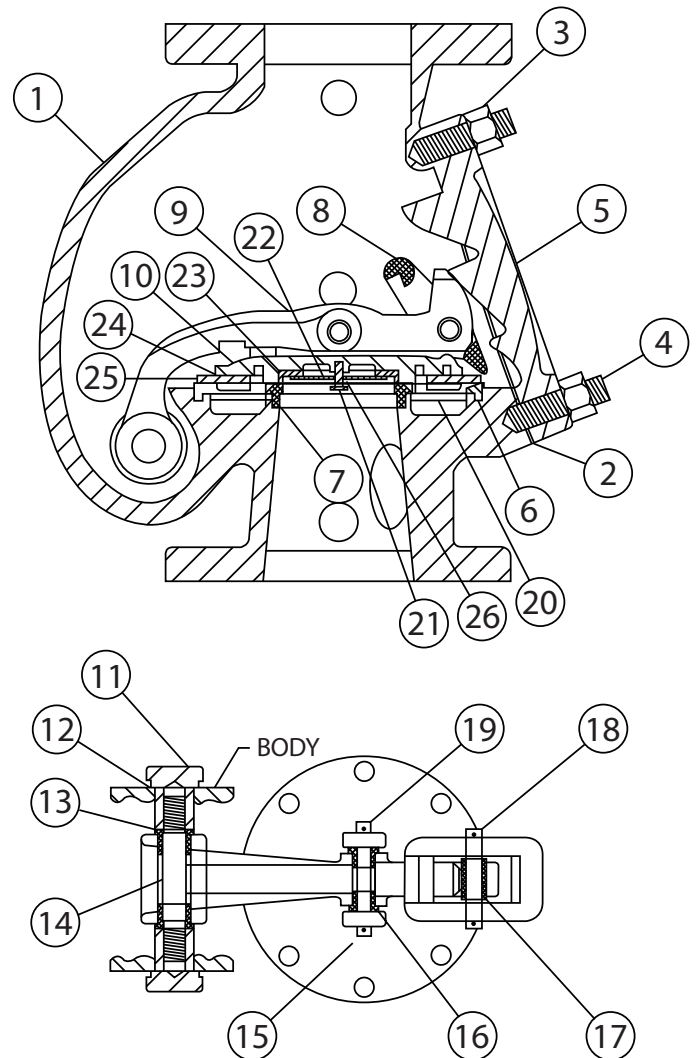

Dry Pipe Valve Model A, B & E

3" - 4" - 6" Dry Pipe Valve (UL/FM Trim)

Parts List

Item No.	Description
1	3", 4" or 6" Dry Pipe Valve
2	3" Valve - 1 1/2" x 5" Galv. Nipple 4" & 6" Valve - 2" x 5" Galv. Nipple
3	3" & 6" Valve - 3/4" x 4" Galv. Nipple 4" Valve - 3/4" x 3 1/2" Galv. Nipple
4	1/4" x 1 1/2" Galv. Nipple
5	3/4" x 4 1/2" Galv. Nipple
6	1/4" x 2" Galv. Nipple
7	3/4" x 2 1/2" Galv. Nipple
8	3/4" x 2" Galv. Nipple
9	3/4" x 3 1/2" Galv. Nipple
10	1/2" x 2 1/2" Galv. Nipple
11	1/2" x 3" Galv. Nipple
12	3" Valve - 3/4" x 4" Galv. Nipple 4" & 6" Valve - 3/4" x 2 1/2" Galv. Nipple
13	3" Valve - 1 1/2" Brass Angle Valve 4" & 6" Valve - 2" Brass Angle Valve

Parts List

Item No.	Description
14	3/4" Brass Angle Valve
15	1/2" Brass Angle Valve
16	1/4" Brass 3 Way Valve
17	3/4" Brass Globe Valve
18	3/4" Brass Ball Valve
19	3/4" Brass Check Valve
20	3/4" Galv. Union
21	3/4" Galv. Close
22	1/2" Galv. Close
23	1/4" Steel Plug
24	3/4" Steel Plug
25	Water Gauge
26	Air Gauge
27	3/4" Galv. Elbow
28	3/4" Galv. Street Elbow
29	1/4" Galv. Street Elbow
30	3/4" x 1/4" Galv. Bushing
31	1/2" x 1/4" Galv. Bushing
32	3/4" Galv. Tee
33	3/4" x 1/2" x 3/4" Galv. Tee
34	1/2" Galv. Tee
35	1/2" Brass D.V.D
36	3/4" Priming Cup
37	1/2" Priming Cup

