



Glycerine Filled Pressure Gauge

Description

100mm glycerine filled, bourdon tube pressure gauge for sprinkler alarm valve and pump house equipment. 3/8" BSP Direct mount bottom entry, supplied with 3/8" to 1/2" BSP no loss connector. Complies with BS EN 837-1

Installation

A Pressure Gauge correctly installed and to the correct specification gives indication of pressure in the system.

- Before fitting the gauge to a pressure source check that the maximum scale value of the gauge is higher than the pressure to be applied. The applied pressure should be 75% of maximum scale value for steady pressures or 65% of maximum scale value for fluctuating pressures.
- Before fitting the gauge to a pressure source check that the wetted parts are compatible with the fluid being used, and that the pressure connection correctly matches that of the pipework.
- When fitting the gauge to the pipework, use correct sealing methods. Do not use the gauge case to tighten the gauge to the pipework, use a correct size spanner on the neck hexagon.
- Do not use glycerine filled gauges for any fluid which has strong oxidizing agents for example chlorine, hydrogen peroxide, nitric acid, etc.
- The ambient and process temperature acting on the gauge should be within -20°C and + 80°C and protected from higher fluid temperature by means of a syphon tube filled with condensate before use. The fluid in the pressure chamber should not be allowed to freeze or crystallise as this will lead to rupture of the sensing element.
- Should the pointer of any pressure gauge not return to zero, when the pressure is removed, it is an indication that damage to the gauge has occurred and the gauge should be replaced immediately.

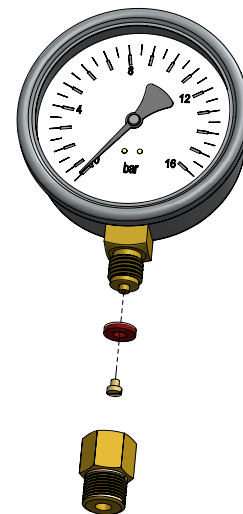
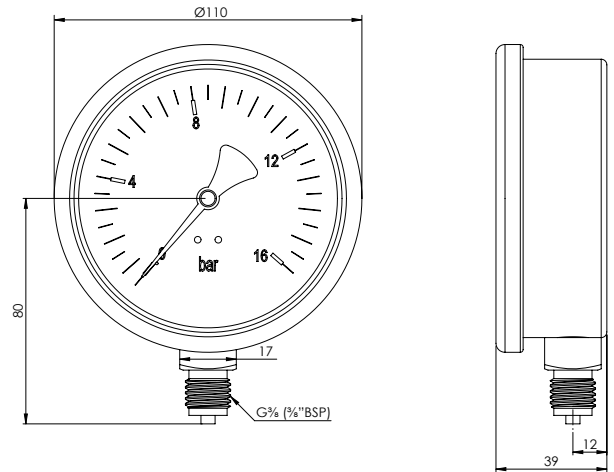

Scale Options

Scale Range (bar)	Product Ordering Code
-1 to +2	RDPRESSGAUGE12
0 to 7	RDPRESSGAUGE7
0 to 16	RDPRESSGAUGE16
0 to 25	RDPRESSGAUGE25
0 to 40*	RDPRESSGAUGE40*
0 to 70*	RDPRESSGAUGE70*

*No loss connector is not supplied with 0 to 40 and 0 to 70 bar gauges

No loss connector is supplied only with gauges rated up to 25bar. When using no loss connector make sure to use supplied screw and seal, otherwise the gauge will not work correctly.