

# Double Interlock Preaction System with 502 Deluge Valve Electric / Pneumatic Release

## General Description

The Double Interlock Preaction System with Electric/Pneumatic Release is generally used to protect water sensitive areas such as computer rooms, storage areas, refrigerated areas etc., to avoid water damage due to inadvertent flooding of the sprinkler system piping.

In normal condition, preaction system does not contain water in the sprinkler piping. The sprinkler piping contains air pressure for the purpose of supervising its leak tightness.

This is most commonly used system. This system utilizes a Deluge Valve Fig.502 and Riser Check Valve Model CH. The Riser Check Valve isolates the Deluge Valve from the system air pressure. Riser Check Valve provides an air check so that the system can be automatically pressurized with a supervisory air or nitrogen pressure of 42 PSI (2.94 Bar). A supervisory low pressure alarm switch can be set at 20 PSI (1.40 Bar), on decreasing pressure, to indicate whether there are any abnormal leaks in the sprinkler system piping. Loss of air pressure from the system due to accidental leakage will not cause Deluge Valve to open.

The releasing trim for Deluge Valve utilizes a Solenoid Valve and a Dry Pilot Actuator in a series configuration. The system air pressure holds the Dry Pilot Actuator closed, whereas the Solenoid Valve remains closed until it is electrically energized by a Deluge Valve Releasing Panel (automatic control unit). The Releasing Panel is operated either by a fire detection device or manual electric pull station. In order for the Double Interlock Pre-Action System to automatically actuate, two independent events must occur. The Deluge Valve Releasing Panel must operate and open the Solenoid Valve upon automatic operation of the electric fire detection initiating circuit and the sprinkler system piping must lose air pressure due to operation of one or more sprinklers. The Double Interlock Pre-Action System will automatically actuate only when both the Dry Pilot Actuator and the Solenoid Valve are open at the same time. Unintended opening of just the Dry Pilot Actuator or the Solenoid Valve will only cause an alarm and not actuate the system or flood the sprinkler system piping.

## Installation & Commissioning

The preaction system valves, panel, indicators must be installed in a readily visible and accessible location. The system valves and accessory shall not be installed in an area having temperature less than 4°C (40°F). Heat tracing to system valve and accessory is not permissible. The system must be installed and operated carefully by a trained person, having good knowledge of equipment. All system piping must be flushed thoroughly before commissioning.

After initial successful tests, an authorized person must be trained to perform inspection, testing and maintenance of the system.



## Technical Details

Nominal Size	DN 50, 80, 100, 150, 200
Deluge Valve	Fig 502 - UL Listed
Check Valve	Model - CH
Sprinkler Alarm	UL Listed (optional)
Release Panel	UL Listed (optional)
Water Flow Switch	UL Listed
Solenoid Valve	24V DC, UL Listed
Automatic Air Supervisor	Oil-Less Risermount Compressor (optional)
Air Pressure Maintenance Device	PMD-1 (optional)
Manual System Shutoff Valve	UL Listed, Butterfly Valve - Standard supply (Gate valve optional)
Maximum Working Pressure	17.2 bar (250 psi)
System End Connection	Flanged (standard supply) Grooved (optional supply)
Approval	UL Listed



# Double Interlock Preaction System with 502 Deluge Valve Electric / Pneumatic Release

## Recommended Sequence of Installation

In planning the installation, consideration must also be given to the disposal of relatively large quantities of water that may be associated with draining of the system or performing flow test.

1. Install the Deluge Valve on Riser in vertical position.
2. Install the Riser Check Valve above Deluge Valve as shown in installation drawing.
3. On completion of system piping, install all the trims as per the trim drawing. Care must be taken to ensure that Check Valves, Strainers, Valves etc. are installed with the flow arrows in the proper direction.
4. Connect all drain piping as shown in the drawing.
5. All unused opening on valve or trim parts must be plugged.
6. Connect air supply line.
7. Connect all electrical to control panel as per wiring drawing.
8. Make sure that all the nut bolts, fittings are screwed properly.
9. Follow the valve resetting and test procedure.
10. The pipe fittings and nipple must be cleaned. Use thread sealant on male threads only.
11. For common drain piping a check valve to be provided interconnecting main drain and the funnel.
12. The drain tubing to be drip funnel must be installed with smooth bends that will restrict flow.
13. The drain piping must be free-flow and care must be taken to direct the drain in proper area to avoid damage due to release of system.
14. A supervisory air or nitrogen supply is to be installed as given in the data sheet. An air dryer, if specified, needs to be installed as per authority having jurisdiction.
15. The electric connection through conduit is to be made as per authority having jurisdiction.

## Resetting Procedure

1. Close the upstream side stop valve of the Deluge Valve.
2. Open drain valves and allow water to drain (if water flow was established) & close drain valve when water flow has ceased.
3. Check all release devices are closed. Inspect the release devices if system was subject to fire condition.
4. Open the air supply line and check the pressure is maintained up to 42 PSI (2.94 Bar). and Control Panel is kept on.
5. Open the priming line so that the diaphragm chamber reads the system water pressure. Open the manual release station partly to vent the air & then close it.
6. Open the upstream side of stop valve to read the Deluge Valve Inlet water supply pressure. The Deluge Valve is set.
7. Check all the trim parts for possible leak.

## Inspection & Maintenance

Inspection and testing is to be carried out only by an authorized and trained personnel. DO NOT TURN OFF the water supply or close any valve to make repair(s) or test the valve, without placing a roving fire patrol in the area covered by the system. Also inform the local security personal and central alarm station, so that there is no false alarm signal. It is recommended to carry out physical inspection of the system at least twice a week. The inspection should verify that no damage has taken place to any components and check for following normal condition of the system. The owner is responsible for maintaining the pre-action system.

## Normal Condition

1. All main valves are open and sealed with tamper proof seal.
2. All drain valves are in closed condition.
3. No leak or drip is detected from drip valve.
4. All water gauge of deluge valve, should show the required pressure.
5. No leak in any trim or other piping.
6. Release panel is on and no abnormal indication are seen.

## Caution

Procedure outlined below will result in operation of associated alarm. Concerned authorities to be informed about the tests before conducting the tests.



# Double Interlock Preaction System with 502 Deluge Valve Electric / Pneumatic Release

### Water Flow Alarm Test

Open the sprinkler alarm gong test valve, the water will flow through sprinkler alarm and/or water flow switch. On satisfactory observation close the alarm test valve.

### Solenoid Valve Test

1. Close the inlet valve of Deluge Valve and open the main drain valve.
2. Close the air supply valve and drain the air pressure by opening drain valve of check valve.
3. Activate the solenoid valve through detector (zone-1) or manual release zone-2.
4. Observe water flow through solenoid valve outlet.
5. Deactivate solenoid valve deactivating the initiating zone (zone-1/ zone-2).
6. Reset the system as resetting procedure.

### Air Supervisory Low Pressure Alarm Test

Release air pressure gradually through valve provided on check valve. When air pressure drops to 6 PSI (0.42 Bar), the supervisory low pressure alarm must be observed. Close the valve & observe that air pressure has been established to 18 PSI (1.26 Bar), the supervisory air pressure alarm must come to normal condition. If required reset the release panel.

### Annual Operation Test

Testing valve operation without causing water supply to the deluge valve.

1. Close the main system valve controlling water supply to the deluge valve.
2. Open the main drain valve provided on deluge inlet side and allow water to drain. When water flow from drain valve has stopped crack open the main system valve and close the main drain valve partly allowing the water pressure at inlet of deluge valve to raise up to 1.4 Kg. / Sq. Cm.(20 PSI) and no more pressure is rising.
3. Actuate the solenoid valve from control panel as per instruction of control panel manufacturer. Deluge Valve must open and water flow must be noticed through drip valve and through solenoid valve. Close the main supply control valve immediately and allow water to drain from drain valve.
4. When water flow has stopped, reset the deluge valve as per resetting procedure.

### Caution

The steps 2 & 3 must be performed very quickly to prevent water flow to riser.

### Caution

The system must be inspected, tested and maintained as instructed above, in addition to the requirement of NFPA or as per requirement of authority having jurisdiction. The owner is responsible for the inspection, testing and maintenance of the system and devices.

# Double Interlock Preaction System with 502 Deluge Valve Electric / Pneumatic Release

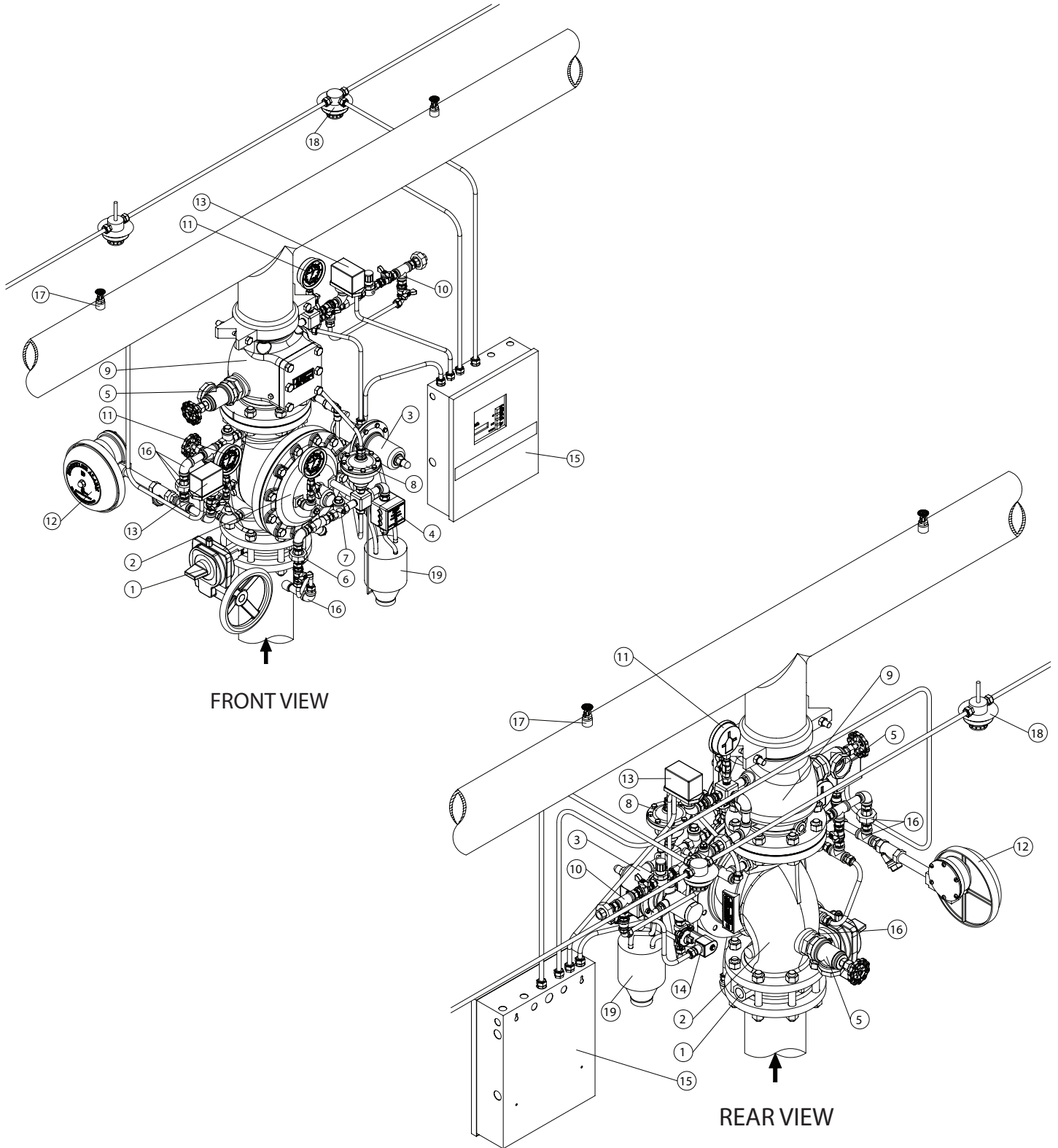



### Double Interlock Preaction System with 502 Deluge Valve Electric / Pneumatic Release

#### Part List

Item	Description	Qty.				
		DN50	DN 80	DN 100	DN150	DN 200
1	Butterfly valve wafer type, gear operated with tamper switch	1	1	1	1	1
2	Deluge Valve Flange End DN50 (2")	1	-	-	-	-
2	Deluge Valve Flange End DN 80 (3")	-	1	-	-	-
2	Deluge Valve Flange End DN 100 (4")	-	-	1	-	-
2	Deluge Valve Flange End DN 150 (6")	-	-	-	1	-
2	Deluge Valve Flange End DN 200 (8")	-	-	-	-	1
3	Dry Pilot Actuator	1	1	1	1	1
4	Emergency Release Station 1/2"	1	1	1	1	1
5	Angle Valve 1 1/4"	2	2	-	-	-
5	Angle Valve 2"	-	-	2	2	2
6	Priming Valve 1/2"	1	1	1	1	1
7	Restricted Check Valve 1/2"	1	1	1	1	1
8	Anti Reset Valve (ARV-1) 1/2"	1	1	1	1	1
9	Check Valve - Flanged x Grooved DN50 (2")	1	-	-	-	-
9	Check Valve - Flanged x Grooved DN80 (3")	-	1	-	-	-
9	Check Valve - Flanged x Grooved DN100 (4")	-	-	1	-	-
9	Check Valve - Flanged x Grooved DN150 (6")	-	-	-	1	-
9	Check Valve - Flanged x Grooved DN200 (8")	-	-	-	-	1
10	Pressure Maintenance Device (PMD-1 1/2") *	1	1	1	1	1
11	Pressure Gauge 0 - 20.7 bar (0 - 300 psi) UL Listed	3	3	3	3	3
12	Sprinkler Alarm (Gong Bell) *	1	1	1	1	1
13	Pressure Switch	2	2	2	2	2
14	Solenoid Valve	1	1	1	1	1
15	Cross Zone DV Releasing Panel *	1	1	1	1	1
16	Trim Fittings	1	1	1	1	1
17	Automatic Sprinkler **	-	-	-	-	-
18	Heat Detector/Smoke Detector **	-	-	-	-	-
19	Splash Proof Funnel	1	1	1	1	1

\* Optional Supply

\*\* To be ordered separately

#### Notes:

- Deluge Valve End Connection (optional - G x G)
- Check Valve End Connection (optional - G x G / F x F)
- Butterfly Valve End Connection (optional - G x G)
- Optional Trim Supply - Semi Assembled
- Shapes of Fittings/Valves may change

Double Interlock Preaction System with 502 Deluge Valve  
Electric / Pneumatic Release

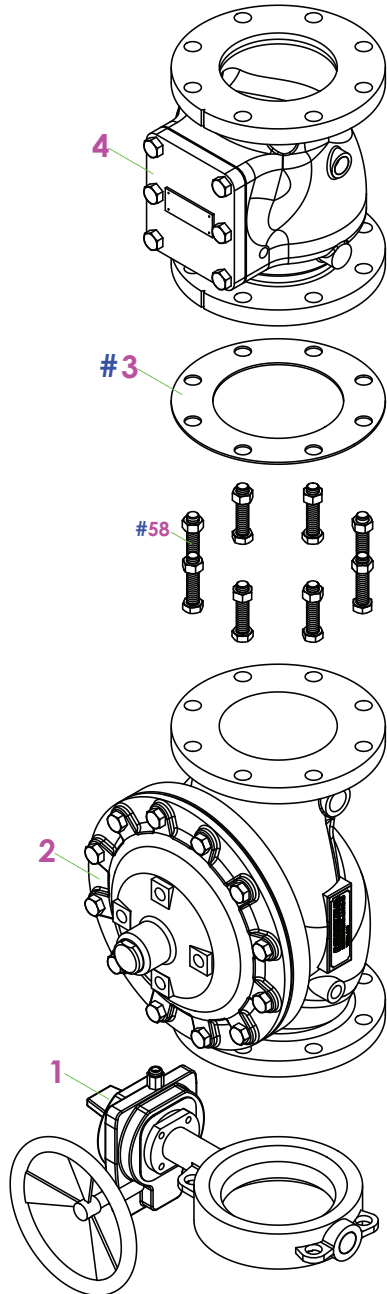

**OPTION - 1**

**Deluge Valve – F x F**  
**Check Valve – F x F**  
**Butterfly Valve – Wafer Type**

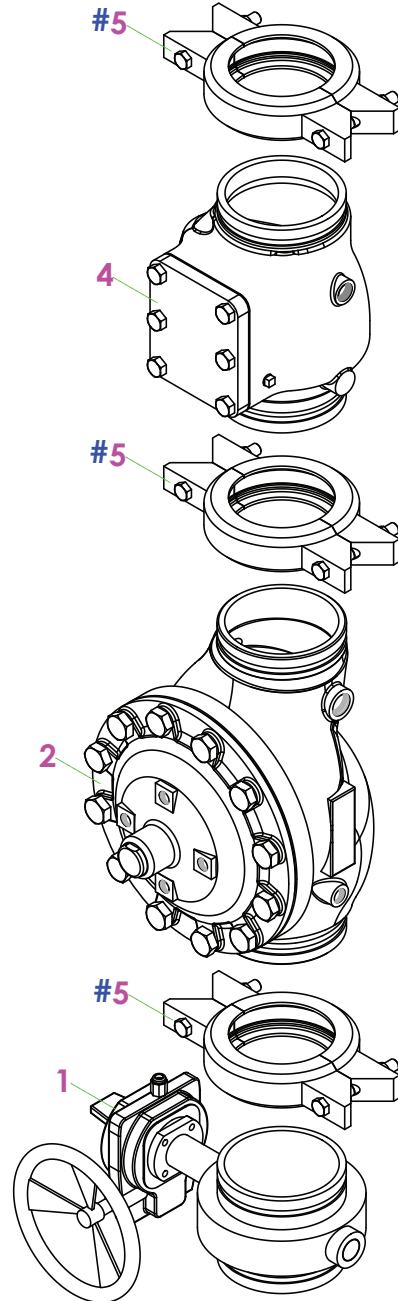

**OPTION - 2**

**Deluge Valve – G x G**  
**Check Valve – G x G**  
**Butterfly Valve – G x G**

### Double Interlock Preaction System with 502 Deluge Valve Electric / Pneumatic Release

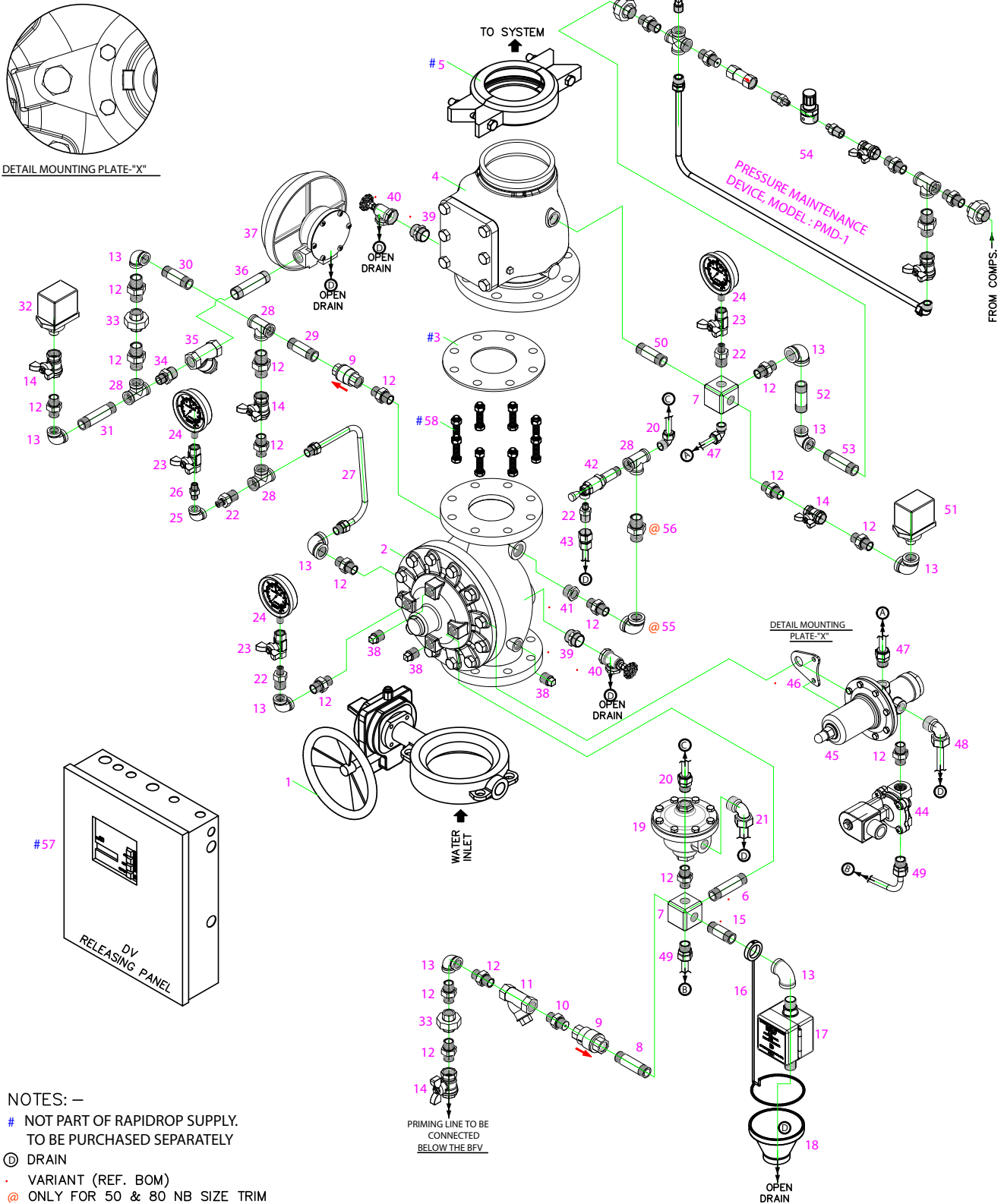

NOTES: -

- # NOT PART OF RAPIDROP SUPPLY. TO BE PURCHASED SEPARATELY
- ⊙ DRAIN
- VARIANT (REF. BOM)
- @ ONLY FOR 50 & 80 NB SIZE TRIM



### Double Interlock Preaction System with 502 Deluge Valve Electric / Pneumatic Release

#### Part List

Item No.	Description	Size	Qty.				
			DN50	DN 80	DN 100	DN150	DN 200
1	Butterfly valve wafer type, gear operated with tamper switch		1	1	1	1	1
2	Deluge Valve Flange End DN50 (2")		1	1	1	1	1
3	Full Face Gasket #		1	1	1	1	1
4	Check Valve - F x G		1	1	1	1	1
5	Rigid Coupling #		1	1	1	1	1
6	Pipe Nipple	1/2" x 100mm	1	-	-	-	-
6	Pipe Nipple	1/2" x 110mm	-	1	-	-	-
6	Pipe Nipple	1/2" x 115mm	-	-	1	-	-
6	Pipe Nipple	1/2" x 120mm	-	-	-	1	1
7	5 Way Manifold	1/2"	2	2	2	2	2
8	Pipe Nipple	1/2" x 60mm	1	1	1	1	1
9	Check Valve	1/2"	2	2	2	2	2
10	Orifice Nipple	1/2"	1	1	1	1	1
11	Y Type Strainer	1/2"	1	1	1	1	1
12	Hex Nipple	1/2"	17	17	17	17	17
13	Elbow	1/2"	9	9	9	9	9
14	Ball Valve	1/2"	4	4	4	4	4
15	Pipe Nipple	1/2" x 60mm	1	1	-	-	-
15	Pipe Nipple	1/2" x 70mm	-	-	1	1	1
16	Funnel Holder	-	1	1	1	1	1
17	Emergency Release Station	1/2"	1	1	1	1	1
18	Funnel	-	1	1	1	1	1
19	Anti Reset Valve (ARV-1)	1/2"	1	1	1	1	1
20	ARV-1 Tubing Assembly	1/2"	1	1	1	1	1
21	ARV-1 Drain Tubing Assembly	1/2"	1	1	1	1	1
22	Reducing Hex Nipple	1/4" x 1/2"	4	4	4	4	4
23	Ball Valve	1/4"	3	3	3	3	3
24	Pressure Gauge	0-300 psi UL Listed	3	3	3	3	3
25	Elbow	1/4"	1	1	1	1	1
26	Hex Nipple	1/4"	1	1	1	1	1
27	Test Alarm Line Assembly	1/2"	1	1	1	1	1
28	Tee	1/2"	4	4	4	4	4

# Not part of Rapidrop supply. To be purchased separately





### Double Interlock Preaction System with 502 Deluge Valve Electric / Pneumatic Release

#### Part List

Item No.	Description	Size	Qty.				
			DN50	DN 80	DN 100	DN150	DN 200
29	Pipe Nipple	1/2" x 60mm	1	1	1	1	1
30	Pipe Nipple	1/2" x 70mm	1	1	1	1	1
31	Pipe Nipple	1/2" x 80mm	1	1	1	1	1
32	Pressure Switch (Water)	1/2" UL Listed	1	1	1	1	1
33	Union	1/2"	2	2	2	2	2
34	Reducing Hex Nipple	3/4" x 1/2"	1	1	1	1	1
35	Y Type Strainer	3/4"	1	1	1	1	1
36	Pipe Nipple	3/4" x 95mm	1	1	1	1	1
37	Sprinkler Alarm (Gong Bell)		1	1	1	1	1
38	SQ. Plug	1/2"	3	3	3	3	3
39	Hex Nipple	1 1/4"	2	2	-	-	-
39	Hex Nipple	2"	-	-	2	2	2
40	Angle Valve	1 1/4"	2	2	-	-	-
40	Angle Valve	2"	-	-	2	2	2
41	Reducing Bush Outside Head	3/4" x 1/2"	1	-	-	-	-
41	Reducing Bush Outside Head	1" x 1/2"	-	1	1	1	1
42	Drip Valve	1/2"	1	1	1	1	1
43	Drip Drain Line Assembly	1/2"	1	1	1	1	1
44	Solenoid Valve	1/2" UL Listed	1	1	1	1	1
45	Dry Pilot Actuator	1/2"	1	1	1	1	1
46	Mounting Bracket	1/2"	1	1	1	1	1
47	DPA Compressor Air Line Assembly	1/2"	1	1	1	1	1
48	DPA Drain Line Assembly	1/2"	1	1	1	1	1
49	SOV Line Assembly	1/2"	1	1	1	1	1
50	Pipe Nipple	1/2" x 80mm	1	1	1	1	1
51	Pressure Switch (Air)	1/2" UL Listed	1	1	1	1	1
52	Pipe Nipple	1/2" x 60mm	1	1	1	1	1
53	Pipe Nipple	1/2" x 60mm	1	1	1	1	1
54	Pressure Maintenance Device	1/2" PMD-1	1	1	1	1	1
55	Elbow	1/2"	1	1	-	-	-
56	Hex Nipple	1/2"	1	1	-	-	-
57	DV Electric Release Panel #	Potter UL Listed	1	1	1	1	1
58	Nut and Bolt Assembly #	M16 x 65 Long	4	-	-	-	-
58	Nut and Bolt Assembly #	M16 x 80 Long	-	4	8	-	-
58	Nut and Bolt Assembly #	M20 x 90 Long	-	-	-	8	8

# Not part of Rapidrop supply. To be purchased separately