



## Dual Port Residential Alarm and Test Valve Assembly

### General Description

Rapidrop offer an innovative, compact and affordable residential alarm valve test assembly for use that covers all the requirements of BS9251 for use in all domestic and residential properties. Valve can be installed in either the vertical or horizontal orientation.

### Features

- Ball valve with lockable handle
- Fewer joints minimises risk of leaks
- Factory fitted pressure gauge
- Dual ports enable the flow switch to be mounted on either side.
- Full bore test valve.
- Glycerine filled 12 bar pressure gauge to EN837-1
- Compact and space saving design
- Quick and easy installation
- Fully compatible with CPVC fire sprinkler systems



### Working Pressure

Max. working pressure 12 bar

### Connections

#### Inlet and Outlet:

Rp (BSP) threads in accordance with ISO7-1

#### Flow Switch Ports:

Rp1 (1" BSP) threads in accordance with ISO7-1

### Standards

Conforms to BS9251:2014

### Flow Switch

#### System Sensor WFDTN switch

- Adjustable signal delay
- Two sets of SPDT contacts
- FM Approved, UL Listed
- Suitable for indoor and outdoor use
- Adjustable sensitivity

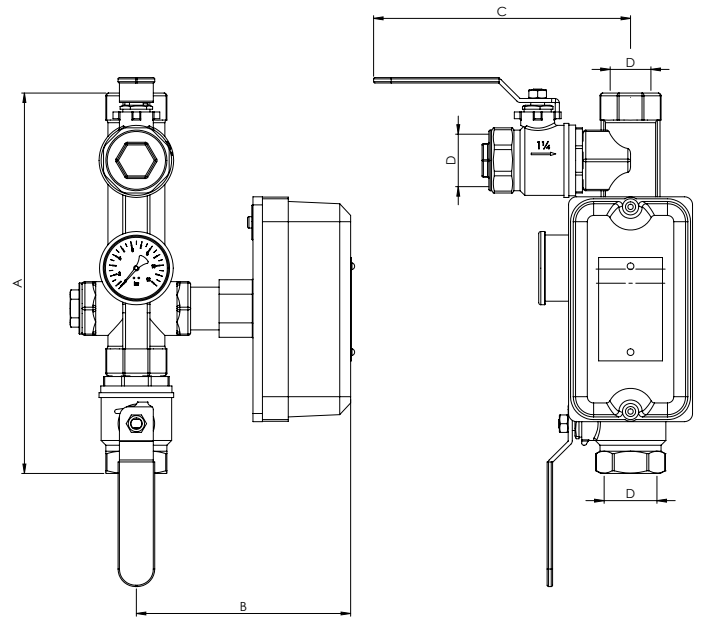

### Dimensions

Riser Size	A	B	C	D
DN25 1"	260	134	164	Rp1 1" BSP Thread
DN32 1 1/2"	278	140	187	Rp1 1 1/4" BSP Thread
DN40 1 1/2"	305	143	197	Rp1 1 1/2" BSP Thread
DN50 2"	335	150	245	Rp1 2" BSP Thread



## Dual Port Residential Alarm and Test Valve Assembly

### Installation Guide

The following notes are intended as a basic guide to assist installation and form part of the manufacturers warranty.

- Ensure correct tools are used for installation, never use grip type tools on the manifold
- Installation should always be carried out by a suitably qualified person
- Always use pipe sealant compatible with all system components. If in doubts please consult manufacturer's product manual.
- When installing the flow switch make sure you use correct size paddle. Ensure the paddle of the flow switch does not interfere with the internal sides of the manifold
- Do not over tighten connecting fittings/components
- The manifold is designed to fit most flow switches. Always check appropriate manufacturers data sheet for suitability
- To ensure the manifold is securely positioned, bracket within 150mm from top and bottom connections

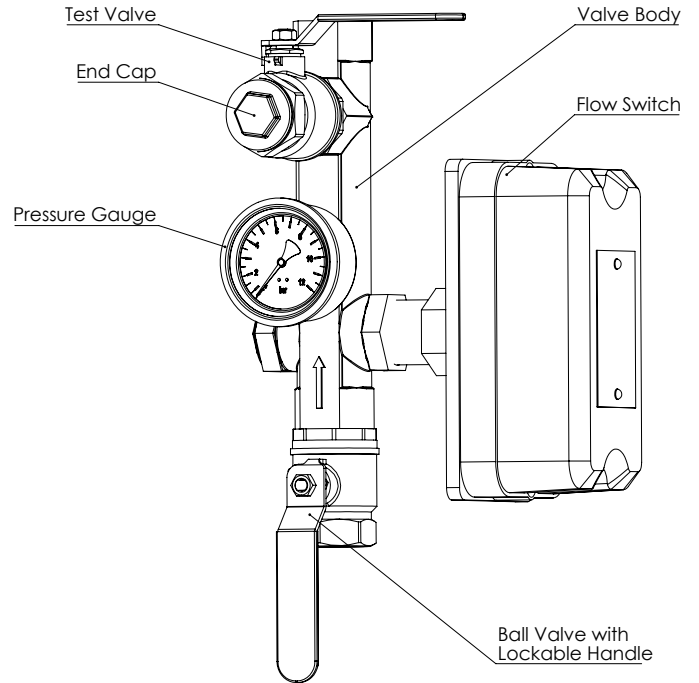

### Wiring Diagram

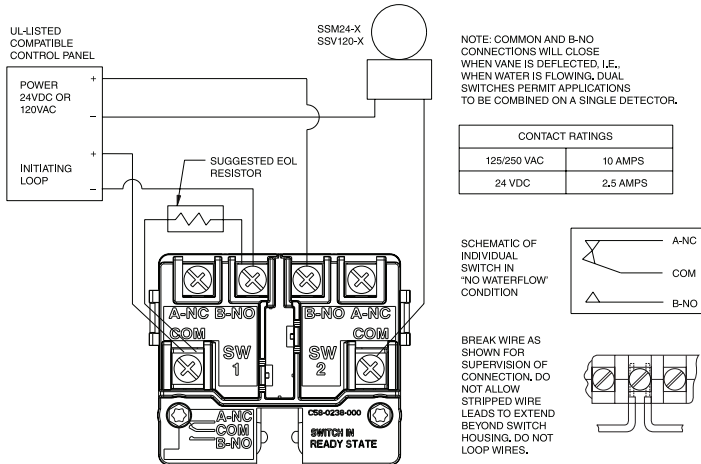

### Material Specification

Number	Part	Material
1	Valve Body	Brass HPb59-1 Nickel Plated
2	Male/female threaded ball valve (with lockable handle)	Brass HPb59-1 Nickel Plated
3	Male/female threaded ball valve	Brass HPb59-1 Nickel Plated
4	End Cap	Brass HPb59-1 Nickel Plated
5	Sealing gasket	PTFE
6	O-Ring	NBR



## Dual Port Residential Alarm and Test Valve Assembly

### System Testing Procedure

1. Ensure that the water to be discharged from the test valve will not cause damage or injury, and that the property owner / occupier is in agreement with the method of discharge.
2. It is recommended that the building occupants and any other interested parties, such as alarm monitoring stations, are notified prior to the alarm test.
3. Connect the test rig, including ideally a calibrated flow meter, onto the test line.
4. Fully open the test valve.
5. Verify the residual (flowing) pressure indicated by the pressure gauge is no less than that originally recorded at the commissioning of the system.
6. Record the litres per minute.
7. Compare the findings with the design criteria of the installed system.
8. If the test fails to achieve the minimum required, trouble shoot as per guidance notes.
9. Ensure a visible or audible alarm (as relevant) is activated.
10. If the test fails to activate the alarm, trouble shoot as per guidance notes.
11. Close the test valve.
12. Remove the test rig.
13. Continue with system specific checks as required.

### Item Number

Item Number	Description
RDRESIVALVESET25DP	DN25 (1") Residential valve set, dual port
RDRESIVALVESET32DP	DN32 (1 1/4") Residential valve set, dual port
RDRESIVALVESET40DP	DN40 (1 1/2") Residential valve set, dual port
RDRESIVALVESET50DP	DN50 (2") Residential valve set, dual port
RDWFDN	WFDN Residential Flow Switch

### Important Installation Information

- Rapidrop Residential Riser must only be installed by a competent person in accordance with requirements of the local authority having jurisdiction. Deviations from these standards will invalidate warranty.
- It is the responsibility of the installing contractor to include a copy of this document in the sprinkler system installation, operating and maintenance manual.
- Alterations to Rapidrop products will void any warranty.
- Residential Riser should be inspected and maintained during routine sprinkler system inspections by a competent person in accordance with national codes/requirements.
- Failure to follow these instructions could cause improper operation, resulting in personal injury and/or property damage.
- For further details and technical support please contact your Rapidrop sales representative.