

Commercial Flush Pendent Sprinkler

Quick Response/Standard Coverage

K5.6 Model: RD101

General Description

The Model RD101 Flush Pendent Sprinklers are automatic sprinklers of the compressed fusible solder type. They are decorative, low profile, flush mounted sprinklers. The Frame and Cover of the sprinkler hide the Deflector and Gasket assemblies. (Reference Figure 1)

The Model RD101 is designed for use in Commercial occupancies. When aesthetics is the major consideration, the Model RD101 should be your first choice.

They are to be used in wet pipe sprinkler systems per NFPA 13.

The Model RD101 has a 5.6 (80.0) K-factor.

The Flush design of the Model RD101 features a separable escutcheon providing 3/8 inch (9.5 mm) vertical adjustment.

This adjustment reduces the accuracy to which the fixed pipe drops to the sprinklers must be cut to help assure a perfect fit installation.

The Model RD101 has been designed with heat sensitivity (Quick Response) and water distribution characteristics proven to help in the control of fires to improve the chance for occupants to escape or be evacuated. However, fire sprinkler systems are not a substitute for intelligent fire safety awareness or fire safety construction required by building codes.



Technical Data

Item Number	Description
Approvals	LPCB,CE
Sprinkler Identification Number (SIN)	RD101
Maximum Working Pressure	175 psi (12.1 bar)
Discharge Coefficient	K80 (K5.6)
Temperature Rating	162°F / 72°C 205°F / 96°C
Vertical Adjustment	3/8 inch (9.5mm)
Finishes	Sprinkler and Escutcheon - White Paint and Chrome Plate.
Physical Characteristics	Dezincification resistant bronze body and copper gasketed orifice seal (Metal Sealing) design

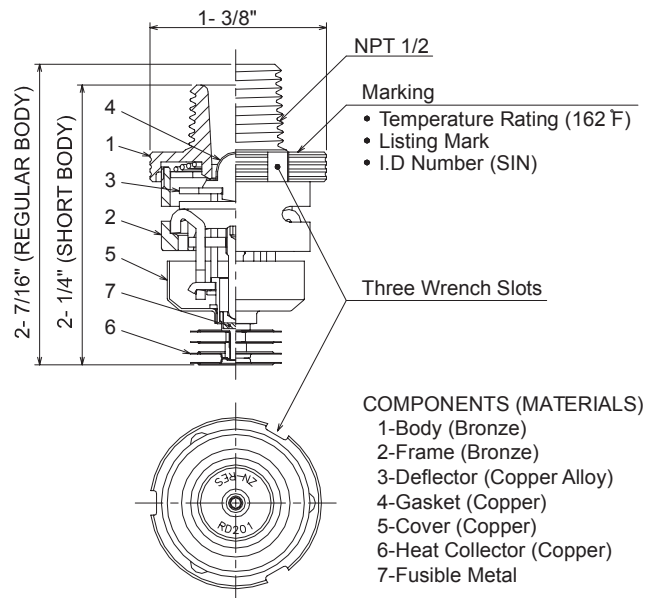

Figure 1

Commercial Flush Pendent Sprinkler

Quick Response/Standard Coverage

K5.6 Model: RD101

Operation

The Sprinkler assembly contains a small fusible solder element. When exposed to sufficient heat from a fire, the solder melts and enables the internal components of the sprinkler to fall away. At this point the sprinkler activates with the deflector dropping into its operated position (Reference Figure 2), permitting water to flow.

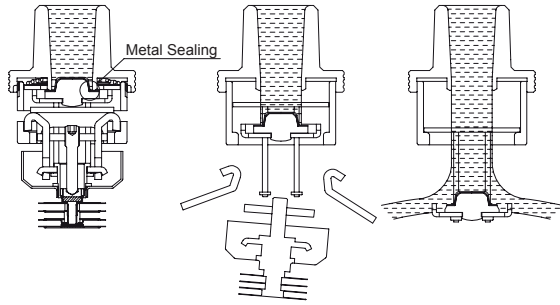

Normal Condition → Operation → Water Discharge

FIGURE 2

Design Criteria

The Model RD101 Flush Pendent Sprinklers must only be installed and utilised in accordance with the following described criteria, which are provided by the manufacturer.

Notes

Fire Sprinkler Systems should only be designed and installed by those component and completely familiar with automatic sprinkler system design, installation procedures, and techniques.

The Model RD101 Flush Pendent Sprinklers are intended for fire protection systems designed in accordance with the standard installation rules recognized by the applicable Listing or Approval agency (e.g., UL Listing is based on NFPA 13 requirements).

Several criteria may apply to the installation and usage of each sprinkler. Consequently, it is recommended that the sprinkler system designer review and develop a working understanding of the complete list of criteria prior to initiating the design of the sprinkler system.

Questions concerning sprinkler installation and usage criteria, which are not coverage by the following instructions, should be submitted to Rapidrop Ltd. Include sketches and technical details as appropriate.

In some instances, the requirements of this document may concern specifications which are more stringent and which take precedence over those specified in NFPA 13 or by the authority having jurisdiction.

The spray from the sprinkler is distributed radially outward and downward from the sprinkler deflector. Consequently, the sprinklers must be located such that there will not be any blind spaces shielded from spray by partitions, room dividers, overhangs or other parts of the dwelling structure.

The number of sprinklers within each compartment (as defined by NFPA 13,) must be kept as few as possible. Do NOT use more sprinklers than necessary to cover a particular space.

Use only the escutcheon provided with the Model RD101.

The sprinkler must be secured in position by firmly fastening the

sprinkler system piping to the structure. If the sprinkler is not properly secured in position, reaction forces resulting from sprinkler operation could alter its orientation and its water distribution pattern.

The sprinkler escutcheon cannot be used to hold the sprinkler in position. The Model RD101 must only be utilized in wet pipe sprinkler systems.

Obstruction to Water Distribution

Locations of sprinklers are to be in accordance with the obstruction rules of NFPA 13.

Precautionary Warnings for Corrosive Environments

Model RD101 should not be installed where they may be subjected to a corrosive environment including the following:

1) Chlorine ion and Chloride environment

Stress corrosion cracking may be caused by exposure to environments with Chlorine ion and Chloride. Exposure to this environment may result in sprinklers operating under non-fire conditions or not operating when exposed to an actual fire.

2) Sprinkler system piping with Copper

Sprinkler systems should be constructed in compliance with the applicable standards and the requirements for the copper piping when copper piping is used in the sprinkler system. (Reference standards NFPA 13, ASTM B813, ASTM B828, and CDA (Copper Development Association) – Solder Joint)

All residual flux must be removed from the interior and exterior of copper piping by thoroughly flushing before installation of the Sprinkler Heads. Otherwise, residues of flux may cause corrosion and leakage in the sprinkler system.

Operational Sensitivity Criteria

For proper operational sensitivity, the model RD101 must be installed beneath a solid ceiling having a smooth or textured surface.

Heat Source Criteria

Refer to NFPA 13 for the requirements relating to preventing the possible release of a Model RD101 heat responsive element, due to exposure to heat sources other than an actual fire.

Installation

The Model RD101 must be installed in accordance with the following instructions:

Notes

Do not use sprinklers which have been subjected to potential mechanical damage. Do not use sprinklers which show deformation or cracking in either the sprinkler or protection cap.

The Protective Cap must remain on the sprinkler during installation and until the ceiling installation is completed. The Protective Cap must be removed to place the sprinkler in service.

A leak tight 1/2-inch NPT sprinkler joint should be obtained with a torque of 7 to 14 ft.lbs. (9.5 to 19.0 Nm). A maximum of 21 ft.lbs. (28.5 Nm) of torque is to be used to install sprinklers. Higher levels of torque may distort the sprinkler inlet with consequent leakage or impairment of the sprinkler.

Do not attempt to compensate for insufficient adjustment in an Escutcheon Plate by under- or over-tightening the sprinkler. Readjust the position of the sprinkler fitting to suit.

Commercial Flush Pendent Sprinkler

Quick Response/Standard Coverage

K5.6 Model: RD101

Installing Procedure

Step 1

The sprinkler must be installed only in the pendent position and with the Sprinkler waterway centerline perpendicular to the mounting surface.

Step 2

Install the sprinkler fitting so that the distance from the face of the fitting to the mounting surface will be nominally 1- 5/32 inch as shown in Figure 3.

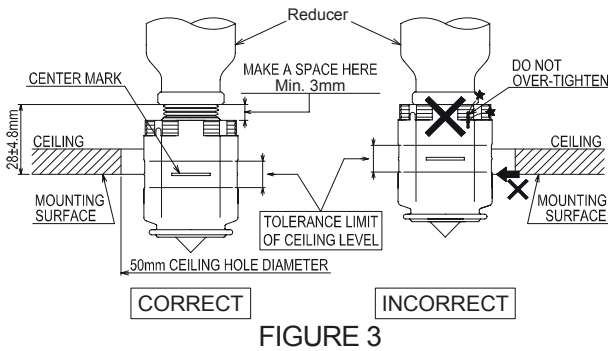

FIGURE 3

Step 3

With pipe thread sealant applied to the pipe threads, hand tighten the Sprinkler into the sprinkler fitting.

Step 4

Wrench tighten the Sprinkler using only the Sprinkler Socket or Wrench & Socket Combination (Ref. Figure 4). The wrench recess of the Socket is to be applied to the sprinkler wrenching area (Ref. Figure 4).

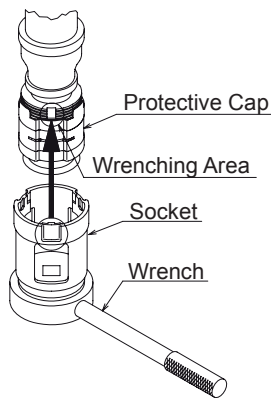

FIGURE 4

Step 5

Use the "tolerance limit of ceiling level" indicator on the Protective Cap to check for proper installation height (Ref. Figure 3). Relocate the sprinkler fitting as necessary. If desired the Protective Cap may also be used to locate the center of the clearance hole by gently pushing the ceiling material against the center point of the Cap.

Step 6

After the ceiling has been completed with the 2-inch (50mm) diameter clearance hole, use the Protective Cap Removal Tool (Ref. Figure 5) to remove the Protective Cap and then push on the Escutcheon until its flange just comes in contact with the ceiling (Ref. Figure 6 & Figure 7).

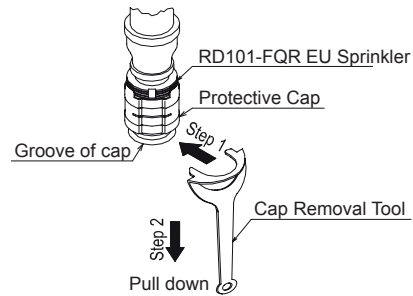

FIGURE 5

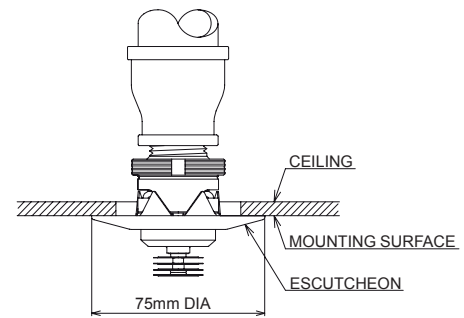

FIGURE 6

Do not continue to push on the Escutcheon such that it lifts a ceiling panel out of its normal position. If the Escutcheon cannot be engaged with the Sprinkler, or the Escutcheon cannot be engaged sufficiently to contact the ceiling, relocate the sprinkler fitting as necessary.

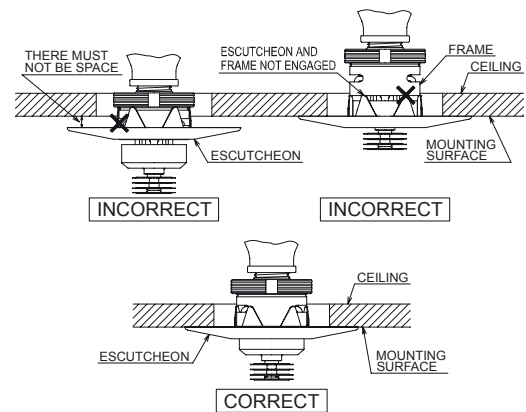

FIGURE 7



Data Sheet 4.12

Issue B



Cert/LPCB/ ref. 566e/01

Commercial Flush Pendent Sprinkler

Quick Response/Standard Coverage

K5.6 Model: RD101

Care and Maintenance

The Model RD101 must be maintained and serviced in accordance with the following instructions:

Notes

Wet pipe sprinkler systems must be maintained at a minimum temperature of 40°F/4°C to prevent freezing and bursting of the pipe and/or sprinklers.

Automatic sprinklers are not to be tested with a heat source. Operation of the heat responsive element can result.

Absence of an Escutcheon Plate may delay the time to sprinkler operation in a fire situation.

Before closing a fire protection system main control valve for maintenance work on the fire protection system, which it controls, permission to shut down the affected fire protection system must be obtained from the proper authorities and all personnel who may be affected by this action must be notified.

Do NOT enclose sprinklers within drapes, curtains, or valances.

Do NOT hang anything from the sprinklers.

Do NOT cleanse the sprinklers with soap and water, detergents, ammonia, cleaning fluids, or other chemicals. Remove dust, lint, cobwebs, cocoons, insects, and larvae by gently brushing with a feather duster or gently vacuuming with a soft bristle (i.e., dusting) brush attachment.

Exercise suitable safety precautions in the use and storage of highly flammable materials. The rapid rate of fire development and spread of which can be caused by such materials can reduce the ability of the sprinkler system to aid in the control of a fire in which they are involved.

Sprinklers, which are found to be leaking or exhibiting visible signs of corrosion, must be replaced.

Automatic Sprinklers must never be shipped or stored where its temperature will exceed 100°F/38°C and they must never be painted, plated, coated, or otherwise altered after leaving the factory. Modified or over heated sprinklers must be replaced.

Care must be exercised to avoid damage to the sprinklers-before, during, and after installation. Sprinklers damaged by dropping, striking, wrench twist / slippage, or the like, must be replaced.

When remodeling, such as by adding false beams or light fixtures or changing the location of compartment walls, first verify that the new construction will not violate the installation requirements stated under WARNINGS. Alter the new construction and/or the sprinkler system to suit the requirements of this document.

The owner is responsible for the inspection, testing, and maintenance of their fire protection system and devices in compliance with this document, the applicable standards of the National Fire Protection Association (e.g., NFPA 25), and the standards of any other authorities having jurisdiction. The installing contractor or sprinkler manufacturer should be contacted relative to any questions.

It is recommended that automatic sprinkler systems be inspected, tested, and maintained by a qualified Inspection Service in accordance with NFPA 25.

Order Procedure

Please Specify:

Sprinkler Head:

Model RD101 K=5.6, Commercial Flush Pendent Sprinkler

Finishes:

White Paint and Chrome Plate.

Temp:

162°F / 72°C 205°F / 96°C

Escutcheon:

Escutcheon for RD101 Flush Pendent Series.
(O. D. 3inch/75mm)

Finishes:

White Paint, Black Paint, and Chrome Plate.

Accessories:

Socket for Model RD101

Wrench & Socket for Model RD101

Protective Cap Removal Tool for Model RD101

Warnings

The Model RD101 Commercial Flush Pendent Sprinklers described herein must be installed and maintained in compliance with this document, as well as with the applicable standards of the National Fire Protection Association, in addition to the standards of any other authorities having jurisdiction. Failure to do so may impair the integrity of these devices.

Because of the above cited stipulations and the varied nature of architecture, there will be some compartment designs which cannot be fully sprinklered in accordance with the recommendations of NFPA 13.

In the event of this condition, consult the authorities having jurisdiction for guidance and approval.

It is the responsibility of the installing contractor to provide a copy of this document to the owner or his representative, and in turn, it is the obligation of the owner to provide a copy of this document to a succeeding owner.

The owner is responsible for maintaining their fire protection system and devices in proper operating condition. The installing contractor or sprinkler manufacturer should be contacted relative to any questions.