



# Lug Butterfly Valve Fig. 217/217 PN16

## Product Description

Rapidrop Figure 217/217 PN16 Lug Butterfly Valve is a rotary type valve with visual indication of whether the valve is in fully open position or not. Butterfly valves are commonly used in fire protection systems as system control valves, sectional or pump water control valves.

These valves have been designed with minimum flow restriction and pressure loss when in fully open position. To reduce the risk of a water hammer Rapidrop Butterfly Valves are provided with a slow close hand wheel operation gearbox.

Valves supplied as standard with a 1m flying lead.

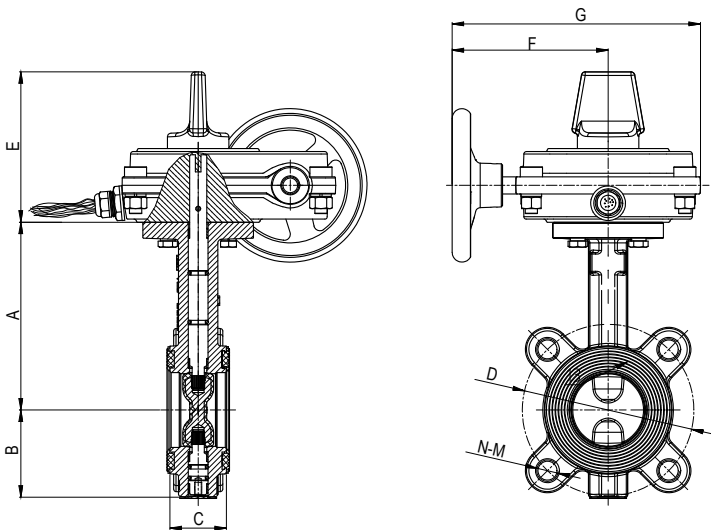

## Coating

Fusion Bonded Epoxy Coating in accordance with ANSI /AWWA C550

## Design Standard

- MSS SP-67
- BS EN593

## Flange Specification

- ANSI/ASME Class 125/150
- BS EN 1092-2 PN16

## Gearbox Mounting Flange

ISO 5211

## Maximum Working Pressure

- 20.7 bar (300 PSI) ≤8"
- 17.2 bar (250PSI) ≥10"

## Temperature Range

0°-80°C

## Sizes

SIZES		Dimensions (mm)										Wgt (Kg)	Pressure Rating Approvals			Product Ordering Code	
In	mm	A	B	C	217		217 PN16		E	F	G		FM	UL	VdS	217	217 PN16
					D	N-M	D	N-M									
2"	DN 50	141	65	43±2	120.7	4- $\frac{5}{8}$ "	125	4 M16	123	127	202	300PSI 20.7bar	300PSI 20.7bar	232 PSI 16bar	RD217-050A	RD217-050	
2.5"	DN 65	153	71	46±2	139.7	4- $\frac{5}{8}$ "	145	4 M16	123	127	202				RD217-065A	RD217-065	
3"	DN 80	158	81	46±2	152.4	4- $\frac{5}{8}$ "	160	4 M16	123	127	202				RD217-080A	RD217-080	
4"	DN 100	176	95	52±2	190.5	8- $\frac{5}{8}$ "	180	8 M16	123	127	202				RD217-100A	RD217-100	
5"	DN 125	191	111	56±2	215.9	8- $\frac{3}{4}$ "	210	8 M16	123	127	202				RD217-125A	RD217-125	
6"	DN 150	203	133	56±2	241.3	8- $\frac{3}{4}$ "	240	8 M20	123	127	202				RD217-150A	RD217-150	
8"	DN 200	244	164	60±2	298.5	8- $\frac{3}{4}$ "	295	12 M20	123	185	260				RD217-200A	RD217-200	
10"	DN 250	273	196	68±2	362	12- $\frac{7}{8}$ "	355	12 M24	123	185	260				RD217-250A	RD217-250	
12"	DN 300	311	226	78±2	431.8	12- $\frac{7}{8}$ "	410	12 M24	132	203	298				RD217-300A	RD217-300	



## Lug Butterfly Valve Fig. 217/217 PN16

### Installation

Rapidrop Figure 217/217 PN16 Lug Butterfly Valves is suitable for indoor and outdoor use. The valves may be installed in any position and the flow may be from either direction through the valve.

The use of additional flange gaskets is not necessary as the valve is self-sealing when connected to the piping system with appropriate flanges (ANSI/ASME Class 125/150 & BS EN 1092-2 PN16).

Valves should be supported independently to prevent the movement and stresses from the connecting piping system.

1. Ensure that the valve is in closed or almost closed position.
2. Visually inspect the valve, make sure the seating area is not damaged and that the connecting flanges are clean of debris and any foreign materials.
  - Insert the valve between the flanges and hand-tighten all flange bolts. Do not use flange gaskets. Do not apply lubricant to the seat faces as this may damage the seat material. Make sure valve is installed centrally between mating flanges.
3. Before fully tightening the bolts, slowly open the valve and check for any interference with the piping system.
  - If the valve opens freely, tighten all flange bolts using the crossover method. Recommended tightening torque is listed in the table.
4. After tightening the bolts check the operation by fully opening and closing the valve.

### Care and Maintenance

Rapidrop butterfly valves require no regular maintenance, however it is advisable to inspect and verify proper operation of the unit annually or in accordance with the authority having jurisdiction.

The inspection should include a visual check for leakage at the pipe connection and body to gearbox connection. Inspection and maintenance should be performed by a competent person in accordance with national codes/ requirements.

Debris in the piping system might cause difficulties in closing the valve, this problem can be fixed by backing off the handwheel and closing the valve again.

Rapidrop Figure 217 & 217 PN16 Lug Butterfly Valves are suitable for both indoor and outdoor use. Minor degradations of surface finish should not affect the performance of the valve.

The valve should never be forced to seat by applying a wrench to the hand wheel as this may distort the valve components or score the sealing surface. The use of excessive force to open or close the valve violates all warranties.

The valve should not be used to force a pipeline into position as this may result in the distortion of the valve body.

### Recommended Bolt Tightening Torque

Size	Recommended Minimum Torque
2"-4" DN50-DN100	30-40 Nm
5"-8" DN125-DN200	45-70 Nm
10" DN250	75-100 Nm
12" DN300	110-150 Nm

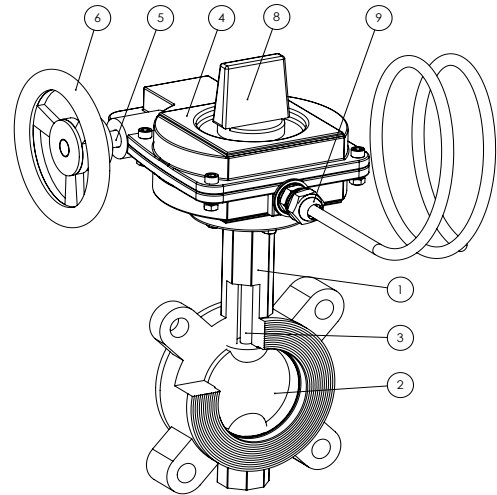

### Material Specification

No	Description	Materials
1	Valve Body	Ductile Iron
2	Disc	Ductile Iron + EPDM
3	Stem	Stainless Steel
4	Gearbox	Ductile Iron
5	Handwheel Shaft	SS431
6	Handwheel	Ductile Iron
7	Seal	EPDM
8	Indicator	Ductile Iron
9	Cable Gland	Plastic

## Lug Butterfly Valve Fig. 217/217 PN16

### Switch Installation

An internal, factory installed, double tamper switch with 1m cables provide easy supervision of the valve. Within two handwheel turns from the "OPEN" position the switch will close indicating that the valve is not fully open.

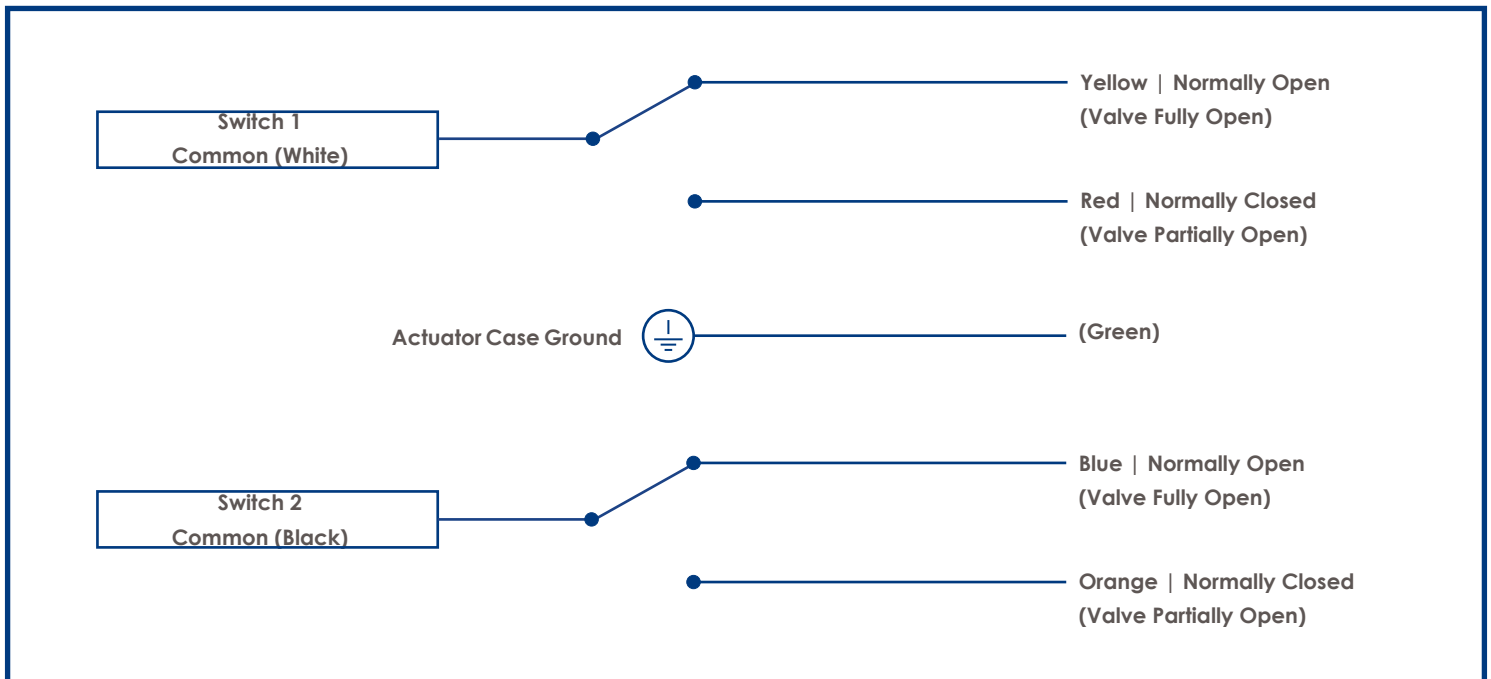

### Important Installation Information

- Rapidrop *Figure 217 & 217 PN16 Lug Butterfly Valves* must only be installed by a competent person in accordance with requirements of the local authority having jurisdiction. Deviations from these standards will invalidate warranty.
- It is the responsibility of the installing contractor to include a copy of this document in the sprinkler system installation, operating and maintenance manual.
- Alterations to Rapidrop products will void any warranty.
- *Figure 217 & 217 PN16 Lug Butterfly Valves* should be inspected and maintained during routine sprinkler system inspections by a competent person in accordance with national codes/requirements.
- Failure to follow these instructions could cause improper operation, resulting in personal injury and/or property damage.
- For further details and technical support please contact your Rapidrop sales representative.